

---

**Instruction  
Manual**

**DX100/DX200  
DAQSTANDARD Software**

IM 04L02A01-61E

---

---

## Foreword

Thank you for purchasing the DAQSTANDARD Software.  
This manual explains how to use the software on Windows 95/98/2000 and NT4.0.  
Please read this manual carefully before operating the software to ensure its correct use.  
After you have read this manual, keep it in a safe place where it can be referred to anytime a question arises.

## Notes

- The contents of this manual are subject to change without prior notice.
- Every effort has been made in the preparation of this manual to ensure accuracy. However, if any questions arise or errors are found in this manual, please inform the nearest Yokogawa sales representative office.
- Copying or reproduction by any means of all or any part of the contents of this manual without permission is strictly prohibited.
- Simultaneous use of this software on two or more computers is prohibited. Simultaneous use by two or more users is also prohibited.
- Transfer or loan of the software to a third party is prohibited.
- Once the software is unpacked, Yokogawa will not guarantee the designed operation of the software, except when the original floppy disk is found to be physically defective.
- Yokogawa will not accept any responsibility for damage caused directly or indirectly as result of use of this software.
- **The serial number will not be reissued, therefore, it must be kept in a safe place.**

## Trademarks

- Windows is a registered trademark of Microsoft Corporation.
- MS-DOS is a registered trademark of Microsoft Corporation.
- Lotus1-2-3 is a registered trademark of Lotus Development Corporation.
- Other product names are trademarks or registered trademarks of the corresponding companies.

## Revisions

|           |               |
|-----------|---------------|
| Sep. 1999 | First edition |
| Sep. 2000 | 2nd edition   |

---

# How to Use this Manual

## Structure of the Manual

This manual consists of the following five chapters and index.

| Chapter | Title  | Content   |
|---------|--|---|
| 1       | Before using the DAQSTANDARD Software          | Explains the PC system environment required for use of the software. Also explains how to install it.                                       |
| 2       | Functions of Launcher                          | Explains Launcher which is used to start the utility programs. Also explains how to set communications between the DX/MV and your computer. |
| 3       | Configuring the DX100/DX200/DX200C/MV100/MV200 | Explains how to set measurement conditions of the DX/MV.  |
| 4       | Displaying Data with the Data Viewer           | Explains how to display data stored in the hard disk etc. Also explains how to convert data to various data formats such as ASCII.          |
| 5       | Troubleshooting                                | Gives a list of error messages and corrective measures.   |
|         | Index  | Gives a list of important terms used in this manual.  |

## Range of Explanation in this Manual

This manual does not provide a description of basic operations of Windows 95/98/2000 and NT4.0. For such descriptions, refer to the Windows User's Guide etc.

## Conventions Used in This Manual

- **Unit**  
K ..... Indicates "1024". (Example: 100KB)
- **Menus, commands, dialog boxes and buttons**  
Enclosed in [ ].
- **Note**  
Provides useful information regarding operation of the software.

# Contents

|   |      |
|---|------|
| Foreword .....  | i    |
| How to Use this Manual .....                                    | ii   |
| <b>Chapter 1 Before using the DAQSTANDARD Software</b>          |      |
| 1.1 Overview of the DAQSTANDARD Software .....                  | 1-1  |
| 1.2 Required PC System Environment .....                        | 1-2  |
| 1.3 Installing the DAQSTANDARD Software .....                   | 1-3  |
| 1.4 Starting/Exiting the Utility Software .....                 | 1-4  |
| <b>Chapter 2 Functions of Launcher</b>                          |      |
| 2.1 Functions of Launcher .....                                 | 2-1  |
| 2.2 Displaying the Version Information .....                    | 2-2  |
| 2.3 Setting the Communication Method .....                      | 2-3  |
| <b>Chapter 3 Configuring the DX100/DX200/DX200C/MV100/MV200</b> |      |
| 3.1 Starting the Configurator .....                             | 3-1  |
| Loading the Setup Data from the DX/MV .....                     | 3-2  |
| Creating Setup Data by Configuring a New System .....           | 3-2  |
| Loading Preexisting Setup Data .....                            | 3-3  |
| 3.2 Setting the Measurement Channels .....                      | 3-4  |
| Input Type (Mode and Range/Type) .....                          | 3-5  |
| Difference Computation and Reference .....                      | 3-5  |
| Display Span .....  | 3-5  |
| Scale .....   | 3-5  |
| Square Root .....   | 3-5  |
| Alarm .....   | 3-6  |
| Input Filter and Moving Average .....                           | 3-6  |
| Tag .....   | 3-6  |
| Display Zone .....  | 3-6  |
| Graph .....   | 3-7  |
| Partial Expanded Display .....                                  | 3-7  |
| Display Color .....   | 3-7  |
| Copying and Pasting Setup Data .....                            | 3-7  |
| Setting One Channel at a Time .....                             | 3-8  |
| 3.3 Setting the Computation Channels .....                      | 3-9  |
| Display Span .....  | 3-10 |
| Alarm and Tag .....   | 3-10 |
| TLOG Computation .....  | 3-10 |
| Rolling Average .....   | 3-10 |
| Display Zone, Graph, Partial Expansion, and Color .....         | 3-10 |
| Constant .....  | 3-10 |
| Setting One Computation Channel at a Time .....                 | 3-11 |
| Copying and Pasting Setup Data .....                            | 3-11 |
| 3.4 Configuring the Settings .....                              | 3-12 |
| Screen Display .....  | 3-12 |
| Message/File .....  | 3-13 |
| Group/Trip Line .....   | 3-14 |

|      |   |      |
|------|---|------|
|      | Setting the View Group (DX200, DX200C, MV200 Only) .....  | 3-15 |
|      | USER Key (DX100, DX200, DX200C, and MV200 Only), Daylight Saving, Batch (Option, When the Style Number is Greater than or Equal to 2) ..... | 3-15 |
| 3.5  | Configuring the Setup Mode .....  | 3-16 |
|      | Alarm/Relay/Remote .....  | 3-16 |
|      | Scan Interval/Memory .....  | 3-17 |
|      | Channel (Setting the Burnout and RJC) .....   | 3-18 |
|      | Key Lock/Login .....  | 3-19 |
|      | Timer (Option) .....  | 3-20 |
|      | Report (Creating Hourly/Daily/Weekly/Monthly Reports) .....   | 3-21 |
|      | Setting the Temperature, Tag, Memory Alarm Time, Displayed Language, and Partial Expanded Display .....                                     | 3-22 |
|      | Network .....   | 3-23 |
| 3.6  | Adjusting the Setup Data (Checking the Data) .....  | 3-25 |
| 3.7  | Sending the Setup Data to the DX/MV .....   | 3-26 |
| 3.8  | Checking the System Configuration and Initializing Setup Data .....   | 3-27 |
| 3.9  | Saving the Setup Data .....   | 3-28 |
| 3.10 | Printing the Setup Data .....   | 3-29 |
| 3.11 | Starting and Stopping Measurement on the DX/MV, Checking the DX/MV System Configuration .....   | 3-30 |
| 3.12 | Characters that can be Used .....   | 3-31 |

## Chapter 4 Displaying Data with the Data Viewer

|      |   |      |
|------|---|------|
| 4.1  | Starting and Exiting the Data Viewer .....                        | 4-1  |
| 4.2  | Displaying the Waveform .....                                     | 4-4  |
|      | General Display Settings .....                                    | 4-5  |
|      | Setting the Time Axis .....                                       | 4-7  |
|      | Setting the Y-axis .....  | 4-8  |
|      | Turn ON/OFF the Alarm Display .....                               | 4-11 |
|      | Selecting the Characters Used to Identify Channels .....          | 4-11 |
|      | Showing/Hiding Cursors .....                                      | 4-12 |
|      | Displaying Cursor's Values .....                                  | 4-13 |
|      | Displaying Statistics .....                                       | 4-13 |
|      | Adding Arbitrary Marks .....                                      | 4-14 |
|      | Searching the Alarm Transition Point and Mark Position .....      | 4-14 |
| 4.3  | Circular Display .....  | 4-17 |
| 4.4  | Displaying Numeric Values .....                                   | 4-19 |
|      | General Display Settings of the Numeric Display .....             | 4-19 |
|      | Setting the Time Axis .....                                       | 4-19 |
|      | Turn ON/OFF the Alarm Display .....                               | 4-19 |
|      | Selecting the Characters Used to Identify Channels .....          | 4-20 |
|      | Showing/Hiding Cursors .....                                      | 4-20 |
|      | Adding Arbitrary Marks, Deleting Marks, and Resetting Marks ..... | 4-20 |
| 4.5  | Linking Files and Saving the Link Settings File .....             | 4-21 |
| 4.6  | Listing Alarms and Marks and Converting the List .....            | 4-23 |
| 4.7  | Displaying the TLOG File .....                                    | 4-25 |
| 4.8  | Saving the Display Settings .....                                 | 4-27 |
| 4.9  | Converting the Data .....   | 4-28 |
| 4.10 | Printing .....  | 4-31 |

**Chapter 5 Troubleshooting**

5. Troubleshooting ..... 5-1

**Index**

**1**

**2**

**3**

**4**

**5**

**Index**

## 1.1 Overview of the DAQSTANDARD Software

The DAQSTANDARD Software consists of the following three utility programs.

- Launcher
- Hardware Configurator
- Data Viewer

### Launcher

Launcher is provided to start the last two utility programs. It also allows you to set communication conditions between the DX/MV and this DAQSTANDARD Software. Launcher and Data Viewer will be automatically registered to the Start menu of Windows when the DAQSTANDARD Software is installed.

### Hardware Configurator

Allows you to set the DX/MV hardware (measurement/math channels, display method etc.). It also allows transfer of the setup data to the DX/MV and saving it to the personal computer's hard disk. Setup data can be set by the following three methods.

**(1) Receiving the setup data from the DX/MV currently connected to the PC**

**(2) Loading existing setup data**

**(3) By configuring a system**

### Data Viewer

Displays the following three types of data generated by the DX/MV and prints them. The data can be displayed graphically or digitally. If you want to open two or more Data Viewers, select [Program] - [DAQSTANDARD Software] - [Viewer] from the Start menu.

- Display data file (.dds)
- Event data file (.dev)
- TLOG file (.dtg)

---

## 1.2 Required PC System Environment

### Hardware

#### **Personal computer**

A computer which runs on Windows 95/98/2000 or Windows NT4.0, and is equipped with Pentium 166MHz or higher (Pentium II 266MHz or higher is recommended)

#### **Main memory**

32MB or more (generally, 64 to 96MB is recommended with Pentium II, though the computer performance depends on the graphic board) However, some application programs may require more memory.

#### **Hard disk**

A free space of 100MB or more

#### **Floppy disk drive**

One floppy disk drive (1.44MB)

#### **Mouse**

A mouse supported by Windows 95/98/2000 or Windows NT4.0

#### **Monitor**

A monitor supported by Windows 95/98/2000 or Windows NT4.0, Resolution: 800 x 600 dots or higher, Number of colors: 32K or more (A monitor with 1024 x 768 dots and 65536 colors is recommended)

#### **Interface board**

For RS-232, a COM port (COM1, COM2, COM3, COM4) which is supported by Windows must be used.

For RS-422-A/RS-485, a converter must be connected to the RS-232 port. This software supports 4-wire system.

For Ethernet, an Ethernet card supported by Windows is required. TCP/IP protocol also needs to be installed.

#### **Printer**

A printer supported by Windows 95/98/2000 or Windows NT4.0 is required. An appropriate printer driver is also required.

### Operating System (OS)

Windows 95/98/2000 or Windows NT4.0

#### **Note**

---

- If your computer runs on Windows 95, Internet Explorer (3.02 or higher) is required.
  - The time zone can be set in [Date/Time] which can be opened from [Control Panel].
  - If daylight saving time is used, mark the check box of "Automatically adjust clock for daylight saving changes".
  - The time zone should not be set using the autoexec.bat file. If "TZ=GTM0" is set in the file, specify "rem" to disable it.
  - Data created in 2038 or later cannot be handled.
  - The font "Courier New" needs to be installed on your personal computer.
-



---

## 1.3 Installing the DAQSTANDARD Software

The DAQSTANDARD Software is provided by two floppy disks. To install the software, an appropriate serial number needs to be entered. The serial number is indicated on the floppy disk #1.

### Operating Method

1. Turn ON the personal computer, then start Windows 95/98/2000 (or WindowsNT 4.0).
2. Insert Floppy Disk #1 into the floppy disk drive.
3. From [Computer], double-click [31/2 Floppy] to open the [31/2 Floppy] window.
4. Double-click the setup.exe file. Installation will start, so follow the instructions displayed in the monitor to complete installation.

### Note

---

- Before starting installation, make sure that all the resident programs such as anti-virus programs are exited.
  - When installation is complete, Launcher and Data Viewer will be registered to the Start menu.
  - To re-install the software, first uninstall it, then re-install it.
  - To uninstall the software, follow the procedure given below.
1. In the [Control Panel], double-click [Add/Remove Programs]. The [Add/Remove Programs Properties] dialog box will appear. From the list, select [DAQSTANDARD Software] and uninstall it.
  2. If necessary, back up the following files to another directory.
    - Setup data file (\*.pnl) and DX/MV data files saved under the directory where the DAQSTANDARD Software has been installed
  3. From Windows Explore, delete all the files (data files and subdirectories) created after installation as well as the directory where the software was installed.
-

## 1.4 Starting/Exiting the Utility Software

### Starting

1. From the Start menu, select [Programs] - [DAQSTANDARD Software] - [Launcher]. Launcher will start, and the following window will appear. If communications have not been set, the [Network] dialog box will appear. Hardware Configurator (CONFIG), Data Viewer (VIEWER) and [Network] dialog box (NETWORK) can be started from Launcher.

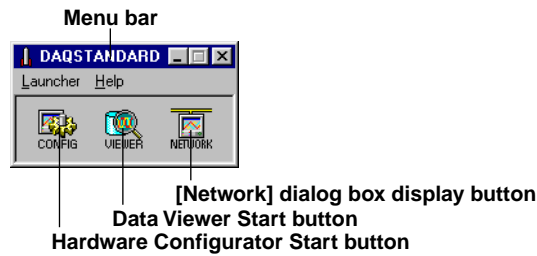

2. Click the start button of the desired utility, or select the desired utility from the Launcher menu.

#### Note

- Once Hardware Configurator, Data Viewer or [Network] dialog box has started, the corresponding start button will be disabled until it is exited.
- If you want to open two or more Data Viewers, select [Program] - [DAQSTANDARD Software] - [Viewer] from the Start menu.
- Once Hardware Configurator has started, it is not possible to open the [Network] dialog box.
- Once the [Network] dialog box is opened, it is not possible to start Hardware Configurator and Data Viewer.

### Exiting

To exit Hardware Configurator or Data Viewer, select [File] - [Exit], or click the [X] button. To exit the [Network] dialog box, click [OK], [Cancel] or [X] button. To exit Launcher, select [Launcher] - [Exit]. or click the [X] button.

#### Note

- Before exiting Launcher, make sure that all the utilities are exited.
- When Launcher is exited, the DAQSTANDARD Software will also be exited.

## 2.1 Functions of Launcher

### Starting

The utilities of the DAQSTANDARD Software can be started from Launcher.

From the Start menu, select [Programs] - [DAQSTANDARD Software] - [Launcher]. Launcher will start, and the following window will appear. If communications have not been set, the [Network] dialog box will appear. Hardware Configurator (CONFIG), Data Viewer (VIEWER) and [Network] dialog box (NETWORK) can be started from Launcher.



### Description of Each Button

The following three tool buttons are available.

|         |   |
|---------|---|
| CONFIG  | Hardware Configurator Start button. Used to start Hardware Configurator. Once Hardware Configurator has started, this button will be disabled.                                    |
| VIEWER  | Data Viewer Start button. Used to start Data Viewer. Once Data Viewer has started, this button will be disabled.  |
| NETWORK | [Network] Dialog Box Display button. Used to open the [Network] dialog box to set communication conditions. Once Hardware Configurator has started, this button will be disabled. |

### Description of Each Menu

The following two menus are available.

|            |                       |  |
|------------|-----------------------|--|
| Launcher   | Hardware Configurator | Same as the CONFIG button                |
|            | Data Viewer           | Same as the VIEWER button                |
|            | Network Configuration | Same as the NETWORK button               |
| Help About |                       | Displays the version number of Launcher. |

---

## 2.2 Displaying the Version Information

To find the version of the DAQSTANDARD Software, display the [About] dialog box.

### Operating Method

1. From the menu bar of Launcher, select [Help] - [About].  
The [About] dialog box will appear.

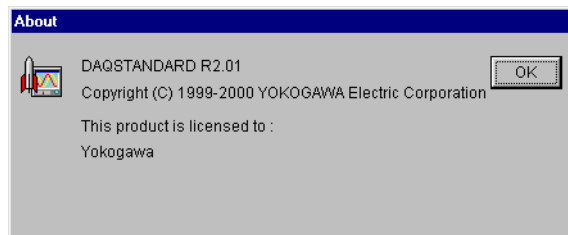

2. To close the dialog box, click [OK].

## 2.3 Setting the Communication Method

Your computer can be communicated with the DX/MV via a network. To use a network, start Network Configurator and set parameters according to the DX/MV.

### Operating Method

1. Click the CONFIG button of Launcher, or select [Launcher] - [Network Configuration] from the menu bar. The [Network] dialog box will appear. Ethernet or serial interface (RS-232 or RS-422A/RS-485) can be used.

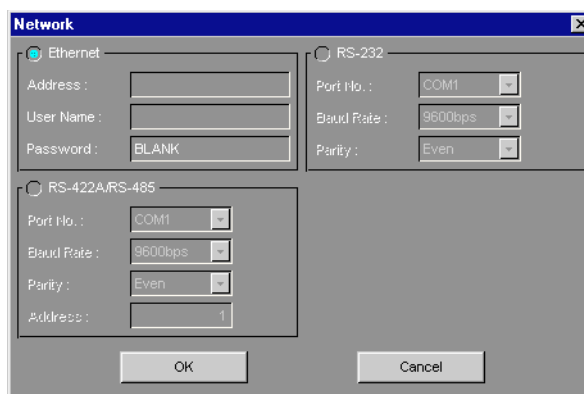

2. Select the desired network type. The color of the selected network will turn to blue.
3. Set each parameter. (For a description of the parameters, refer to “Description of Each Parameter”.)
4. When all the parameters are set, click [OK]. To cancel the settings, click [Cancel].  
The dialog will close, and the settings will be reflected to enable communications. (If communications are in progress, the dialog will close and communications will be re-started.)

### Description of Each Parameter

#### Ethernet

- Address : Specify the IP address or host name.  
 User Name : Specify the user name.  
 Password : Specify the password of the user name.

#### Serial interface (RS-232 or RS-422A/RS-485)

- Port No. : Specify the port no. (COM1 to COM4) to be used.  
 Baud Rate : Specify the baud rate (2400 to 38400).  
 Parity : Specify the parity check (None, Odd or Even).  
 Address : Specify the address (for RS-422A/RS-485 only)

# 3.1 Starting the Configurator

The Configurator can transmit and receive the setup data, change the setup data, and create new setup data. It can configure the following style numbers of DX and MV.

| DX/MV  | Style1                | Style2                | Style3                |
|--------|-----------------------|-----------------------|-----------------------|
| DX100  | <input type="radio"/> | <input type="radio"/> | <input type="radio"/> |
| DX200  | <input type="radio"/> | <input type="radio"/> | <input type="radio"/> |
| DX200C | <input type="radio"/> | <input type="radio"/> | <input type="radio"/> |
| MV100  | <input type="radio"/> | <input type="radio"/> | <input type="radio"/> |
| MV200  | <input type="radio"/> | <input type="radio"/> | <input type="radio"/> |

## Starting the Hardware Configurator

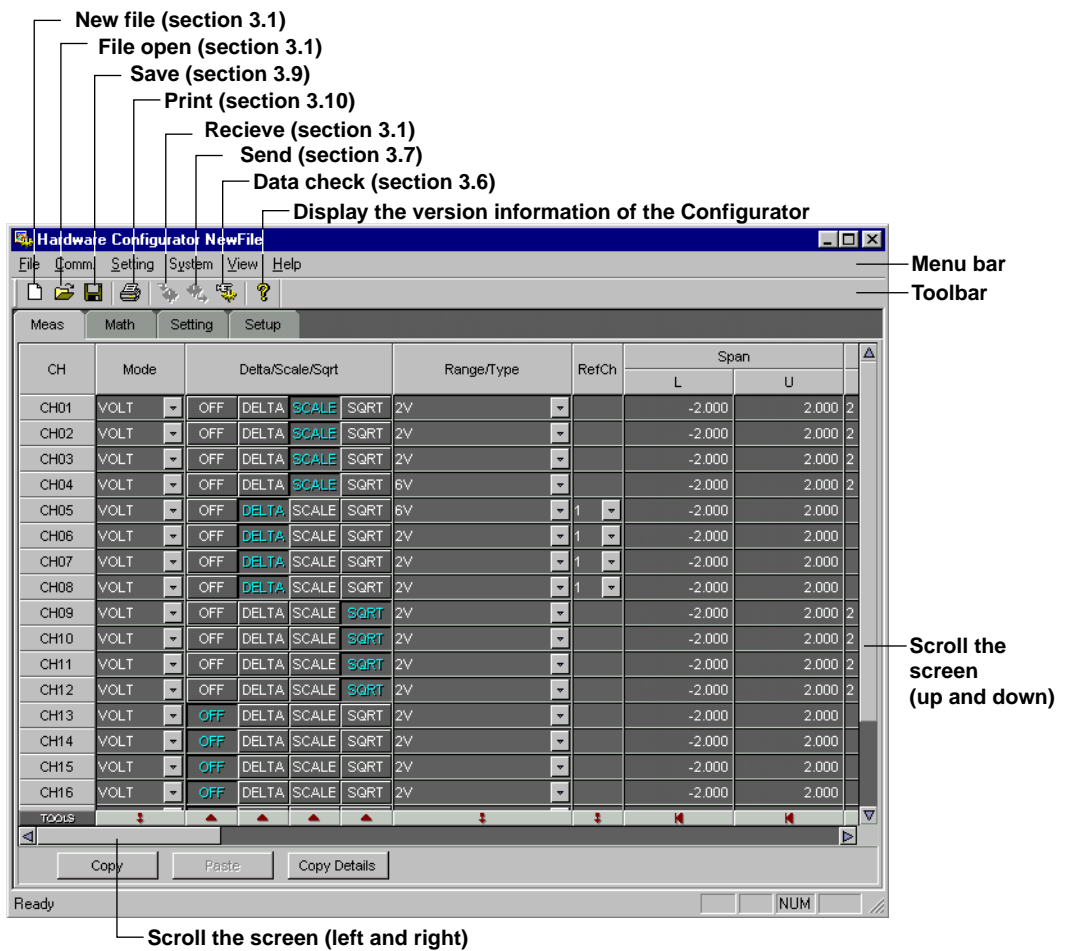
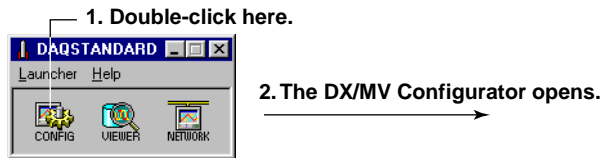

### 3.1 Starting the Configurator

#### Loading the Setup Data from the DX/MV

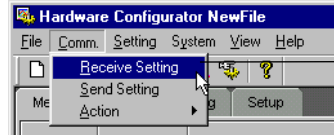
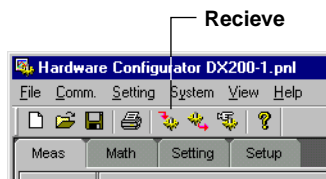

1. Click the Recieve icon or select [Comm.] - [Recieve Setting].

2. The [Recieve Data] dialog box opens.

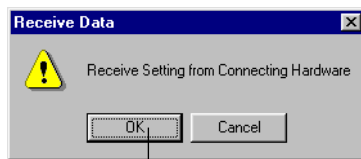

3. Click the [OK] button to recieve the setup data.

#### Creating Setup Data by Configuring a New System

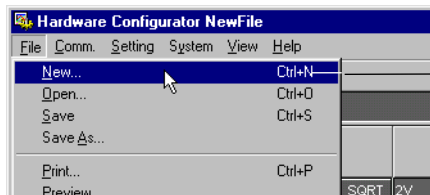
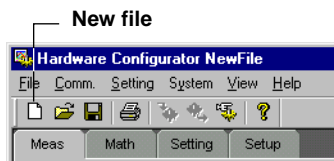

1. Click the new file icon or select [File] - [New].

2. The [System Configuration] dialog box opens.

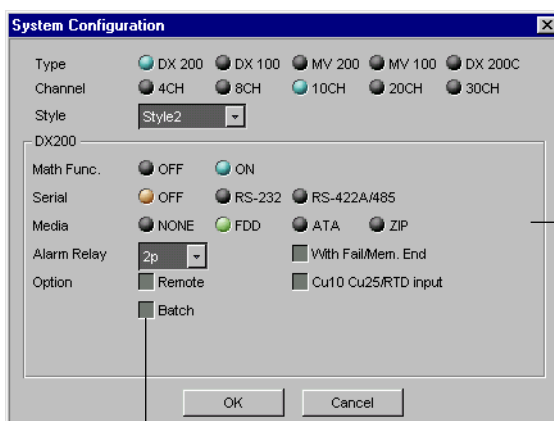

3. Click the appropriate items and click the [OK] button to open the Configurator screen.

Batch function option is selectable when the style number is greater than or equal to 2

### Loading Preexisting Setup Data

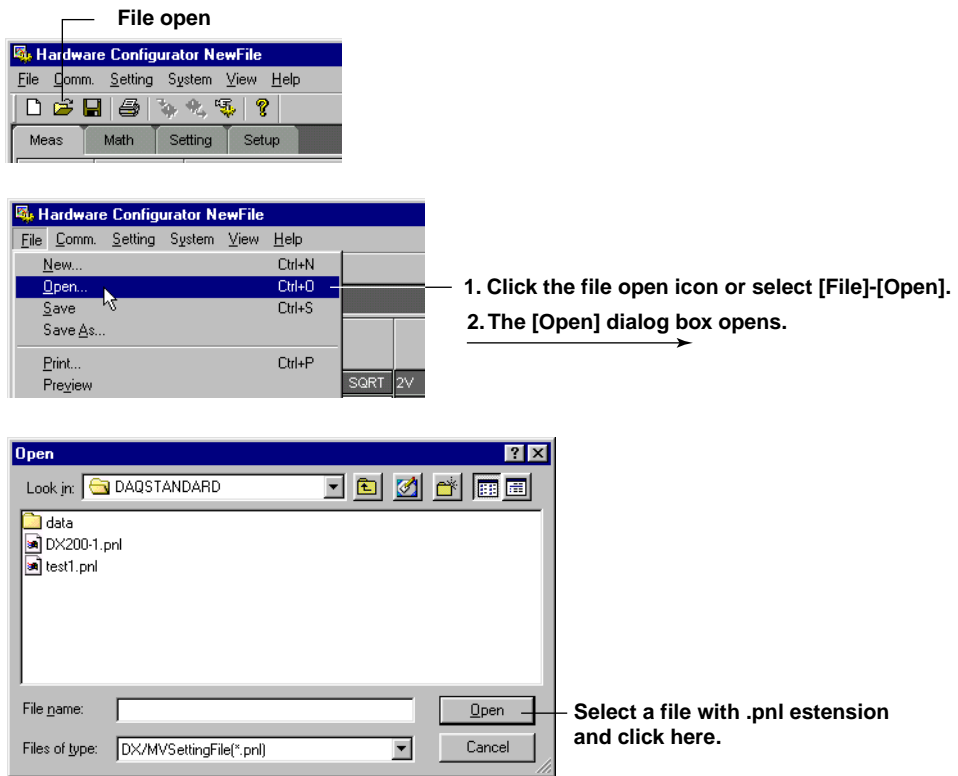

You can specify the location where the setup data file is located and open the Configurator.



## 3.2 Setting the Measurement Channels

Select this tab

Double-click to set the channel

Select the input mode

Difference computation

Scale

Square root

Select the range/type

Select the reference for the difference computation

Set the span

| CH   | Mode | Delta/Scale/Sqrt |       |       | Range/Type | RefCh | Span |        |       |
|------|------|------------------|-------|-------|------------|-------|------|--------|-------|
|      |      | Delta            | Scale | Sqrt  |            |       | L    | U      |       |
| CH01 | VOLT | OFF              | DELTA | SCALE | SQRT       | 2V    | 1    | -2.000 | 2.000 |
| CH02 | VOLT | OFF              | DELTA | SCALE | SQRT       | 2V    |      | -2.000 | 2.000 |
| CH03 | VOLT | OFF              | DELTA | SCALE | SQRT       | 2V    |      | -2.000 | 2.000 |
| CH04 | VOLT | OFF              | DELTA | SCALE | SQRT       | 2V    |      | -2.000 | 2.000 |

Set the selected range at once

Turn OFF at once

Copy the settings of the first channel in the selected range to all other channels

Initialize

Enter the scale

Enter the scale unit

Select the alarm type

Enter the alarm value

Select the relay number

| Point | Scale |        | Unit | Type | Alarm 1 |       |      |
|-------|-------|--------|------|------|---------|-------|------|
|       | L     | U      |      |      | Value   | Relay | Type |
| 2     | 0.00  | 200.00 |      | OFF  | 0.000   | NONE  | OFF  |
| 2     | 0.00  | 200.00 |      | OFF  | 0.00    | NONE  | OFF  |
|       |       |        |      | OFF  | 0.000   | NONE  | OFF  |
|       |       |        |      | OFF  | 0.000   | NONE  | OFF  |

Set the value to the maximum value possible

Set the value to the minimum value possible

Enter the delay period

Enter the tag name

| Alarm 4 |       |       | Alarm Delay | Moving Ave | Tag |
|---------|-------|-------|-------------|------------|-----|
| Type    | Value | Relay |             |            |     |
| OFF     | 0.000 | NONE  | 10 sec      | OFF        |     |
| OFF     | 0.00  | NONE  | 10 sec      | OFF        |     |
| OFF     | 0.00  | NONE  | 10 sec      | OFF        |     |
| OFF     | 0.000 | NONE  | 10 sec      | OFF        |     |
| OFF     | 0.000 | NONE  | 10 sec      | OFF        |     |

Select sampling count

Enter the display zone

Select the graph setting

Turn ON/OFF the partial expanded display

Select the channel display color

| Zone |     | Graph |          |       | Partial   |          |       | Color      |
|------|-----|-------|----------|-------|-----------|----------|-------|------------|
| L    | U   | Div   | Bargraph | Scale | Expand(%) | Boundary |       |            |
| 0    | 100 | 10    | Normal   | 1     | OFF       | 50       | 0.000 | Cyan       |
| 0    | 100 | 10    | Normal   | 1     | OFF       | 50       | 0.000 | Light Blue |
| 0    | 100 | 10    | Normal   | 1     | OFF       | 50       | 0.000 | Blue       |
| 0    | 100 | 10    | Normal   | 1     | OFF       | 50       | 0.000 | Purple     |
| 0    | 100 | 10    | Normal   | 1     | OFF       | 50       | 0.000 | Red        |

Initialize

Set the value to the maximum value possible

Set the value to the minimum value possible

Turn ON/OFF at once

## Input Type (Mode and Range/Type)

Select from the list of choices from the pull-down menu.

| Mode                                  | Relevant Settings         |
|---------------------------------------|---------------------------|
| VOLT (voltage)                        | Range, span L, and span U |
| TC (thermocouple)                     | Type, span L, and span U  |
| RTD (resistance temperature detector) | Type, span L, and span U  |
| DI (voltage level/contact input)      | Range, span L, and span U |
| SKIP (Measurement/Display OFF)        | None                      |

### Note

- When a value outside the range is entered or when the span L and span U values are set to the same value, they are corrected when the data are checked.
- If SKIP is selected, settings such as Delta/Scale/Sqrt and Range/Type are discarded.

## Difference Computation and Reference

Displays the difference between the input and the reference channel.

If difference computation is performed between channels that have different range and type settings, the decimal position of the computed result is set to that of the channel computing the difference. If the number of digits to the right of the decimal of the reference channel is greater than that of the channel computing the difference, the reference value below the least significant digit of the channel computing difference is rounded beforehand.

## Display Span

Sets the upper and lower limits (full scale) of the display.

When the span L and span U values are set to the same value or when a value outside the range is entered, they are corrected when the data are checked.

## Scale

### Scale L, scale U, and decimal point

Scale's value is displayed by taking the range between scale L and scale U to be full scale.

Enter the upper and lower limit values to which you wish to convert the raw values. Include the decimal point.

When the scale L and scale U values are set to the same value or when a value outside the range is entered, they are corrected when the data are checked.

### Unit

Enter the unit using up to six characters.

## Square Root

Computes and displays the square root of the input. This setting can be used only when the input mode is set to VOLT (voltage). As necessary, set the span, scale, and unit.

### Alarm

Four alarms (Alarm 1 to 4) can be specified on each channel.

#### Type

Select H, L, h, l, R, T or t. T or t is selectable when the style number is greater than or equal to 2. The selectable alarms vary depending on the input mode and computation type. For details, see section 6.2 in the DX100/DX200/DX200C/MV100/MV200 User's Manual.

#### Alarm value

Alarm is generated using the specified value as the boundary. The selectable range of alarm values vary depending on the input mode and range.

#### Alarm delay

Alarm is generated when the measured value stays above or below the specified alarm value for the specified time (delay period).

#### Relay

To output relays, select the output relay number. Otherwise, select [NONE].

### Input Filter and Moving Average

Moving average can be specified on models DX106, DX112, DX210, DX220, DX230, MV106, MV112, MV210, MV220, and MV230.

Input filter can be specified on models DX102, DX104, DX204, DX208, DX204C, DX208C, MV102, MV104, MV204, and MV208.

#### Input filter

To use the input filter, select the time constant (2 s, 5 s, or 10 s).

#### Moving average

To use the moving average, select the sampling count (2 to 16).

### Tag

Up to 16 characters can be entered for the tag.

You can use the tag name instead of the channel name to be displayed on the screen.

The [Setup] screen is used to select whether to display the channel name or the tag name on the screen.

If tag is selected in the [Setup] screen, you will be able to select tag No., tag comment, or tag in the Data Monitor or Data Viewer.

### Display Zone

You can select the range of the screen in which the waveform of each channel is to be displayed.

Specify positions (%) on the display scale for the upper and lower limits.

The conditions for setting the zones are as follows:

- Range: 0% to 100%  
The lower limit must be less than the upper limit
- The difference between the lower and upper limits is at least 5%.

## Graph

### Divisions

Select the number of bar graph divisions.

### Bar graph

Select the reference position of the bar graph. Selecting [Center] when the bar graph is vertical produces no effect.

It is set back to [Normal] when the data are checked.

### Scale

When using scale display on the trend screen, select the position to display the scale.

For details related to divisions, bar graph, and scale, see section 7.10 in the DX100/DX200/DX200C/MV100/MV200 User's Manual.

## Partial Expanded Display

### Position (%)

Set the boundary for the partial expanded display. The range is from 1 to 99%.

### Boundary

The conditions used to set the boundary vary depending on the measurement and computation channels as follows:

- Measurement channel
  - When SCALE and SQRT are not used:  $\text{Span L} < \text{boundary} < \text{span U}$
  - When SCALE and SQRT are used:  $\text{Scale L} < \text{boundary} < \text{scale U}$
- Computation channel
  - $\text{Span L} < \text{boundary} < \text{span U}$

### Note

---

The partial expansion settings take effect when the partial expansion function is set to [Use] in the [Aux] section of the [Setup] tab.

---

## Display Color

You can select the display color of each channel from 16 colors.

## Copying and Pasting Setup Data

The items checked in [Copy Details] can be copied and pasted. Click the channel number to select the copy source or paste destination.

To select multiple channels to be copied, drag the channel number to specify the range to be copied. To select multiple copy destinations, select the range in a similar fashion.

### 3.2 Setting the Measurement Channels

#### Setting One Channel at a Time

1. Double-click the channel you wish to set.

| Meas | Math | Setting     | Setup    |
|------|------|-------------|----------|
| CH   | Mode | Delta/Scale |          |
| CH01 | VOLT | OFF         | DELTA SC |
| CH02 | VOLT | OFF         | DELTA SC |
| CH03 | VOLT | OFF         | DELTA SC |

2. The channel setting dialog box opens.

3. Select the tab of the item to be configured.

4. After setting the items, click here. Apply the settings.

Update according to the changes in the [Meas] sheet.

The items in the measurement channel tab can be configured for each channel. The items that are configured are the same as those configured on the spreadsheet. For details, see the page corresponding to the item.

### 3.3 Setting the Computation Channels

Double-click when setting each channel  
 Select this tab  
 Turn ON/OFF computation  
 Enter the expression  
 Set the display span (6 characters or less)  
 Enter the unit  
 Enter the constant to be used in the expression  
 Turn ON/OFF at once  
 Copy the settings of the first channel in the selected range to all other channels  
 Initialize

Set the alarm (section 3.2)

| Alarm 1 |       |       | Alarm 2 |       |       |
|---------|-------|-------|---------|-------|-------|
| Type    | Value | Relay | Type    | Value | Relay |
| OFF     | 0.00  | NONE  | OFF     | 0.00  | NONE  |
| OFF     | 0.00  | NONE  | OFF     | 0.00  | NONE  |
| OFF     | 0.00  | NONE  | OFF     | 0.00  | NONE  |
| OFF     | 0.00  | NONE  | OFF     | 0.00  | NONE  |

Enter the alarm period  
 Enter the tag (section 3.2)  
 Copy the settings of the first channel in the selected range to all other channels

| Alarm Delay | TLOG  |           | Rolling Average |       | Tag |
|-------------|-------|-----------|-----------------|-------|-----|
|             | Timer | Sum Scale | Interval        | Times |     |
| 10 sec      | 1     | OFF       | OFF             | 10s   | 1   |
| 10 sec      | 1     | OFF       | OFF             | 10s   | 1   |
| 10 sec      | 1     | OFF       | OFF             | 10s   | 1   |
| 10 sec      | 1     | OFF       | OFF             | 10s   | 1   |

Display zone (section 3.2)  
 Set the graph (section 3.2)  
 Partial expansion (section 3.2)  
 Display color (section 3.2)

| Zone |     | Graph |          |       | Partial   |          | Color |
|------|-----|-------|----------|-------|-----------|----------|-------|
| L    | U   | Div   | Bargraph | Scale | Expand(%) | Boundary |       |
| 0    | 100 | 10    | Normal   | 1     | OFF       | 50       | 0.00  |
| 0    | 100 | 10    | Normal   | 1     | OFF       | 50       | 0.00  |
| 0    | 100 | 10    | Normal   | 1     | OFF       | 50       | 0.00  |
| 0    | 100 | 10    | Normal   | 1     | OFF       | 50       | 0.00  |

#### Turning ON/OFF Computation

Select whether or not to perform computation for each channel.

#### Expression

Enter the expression using up to 40 characters. For details related to the expression, see the DX100/DX200/DX200C/MV100/MV200 User's Manual.

### 3.3 Setting the Computation Channels

---

#### Display Span

Sets the upper and lower limits of the display.

The range is from -9999999 to 99999999. Set the number of digits to the right the decimal to four digits or less.

#### Alarm and Tag

The settings are the same as the measurement channels. For details, see section 3.2, "Setting the Measurement Channel."

#### TLOG Computation

##### Timer

Select one of the timers (1 to 3) set in the setup mode.

The computation interval of TLOG computation is set to the time assigned to the selected timer.

##### Sum scale

Set the sum scale.

#### Rolling Average

##### Interval

Select the sampling interval when rolling average is activated.

##### Times (Number of samples)

Select the number of samples (number of data points used to compute the rolling average).

#### Display Zone, Graph, Partial Expansion, and Color

The settings are the same as the measurement channels. For details, see section 3.2, "Setting the Measurement Channel."

#### Constant

You can set constants to be used in the expression. Up to 12 and 30 constants can be specified on the DX100/MV100 and DX200/DX200C/MV200, respectively.

### Setting One Computation Channel at a Time

1. Double-click the channel you wish to set.

2. The channel setting dialog box opens.

3. Select the tab of the item to be configured.

Click here to enter the operator

4. After setting the items, click here.

Set the maximum value.

Set the minimum value.

Copy the first setting.

<Select Operator dialog box>

Select the operator type and click the operator button

Operator button

The items in the math channel tab can be configured for each channel. The items that are configured are the same as those configured on the spreadsheet. For details, see the page corresponding to the item.

### Copying and Pasting Setup Data

See section 3.2, "Setting the Measurement Channel."



## 3.4 Configuring the Settings

### Screen Display

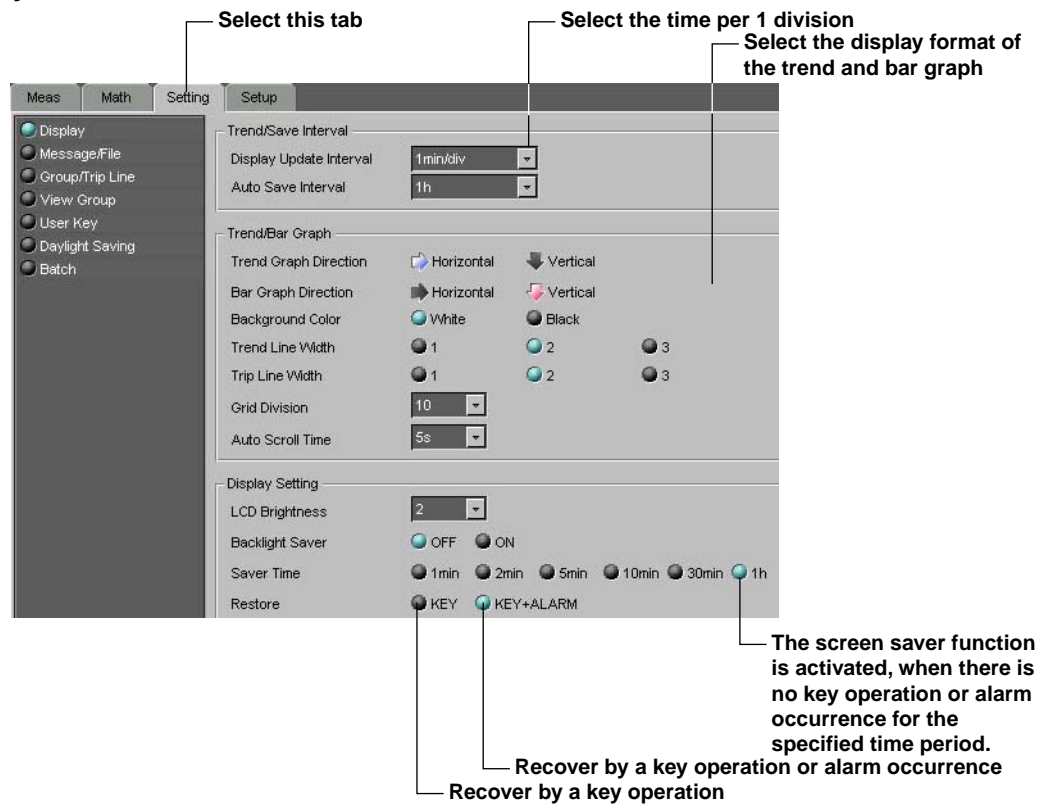

If you selected MV100 in the “System Configuration” dialog box, “User key” on the “Setting” page will not be displayed.

#### Display update interval

You can select the display update interval from 1 min/div, 2 min/div, 5 min/div, 10 min/div, 20 min/div, 30 min/div, 1 h/div, 2 h/div, and 4 h/div. In addition to these selections, 15 sec/div and 30 sec/div can also be selected on the MV102, MV104, MV204, and MV208 when the style number is greater than or equal to 3.

#### Auto save interval

The auto save interval can be specified when the [Save] is set to [Auto] (see page 3-17) and the data type is set to [DISPLAY] or [EVENT&DISP] in the memory sample section of the setup tab.

#### Auto scroll time

This is the time period used to automatically switch the displayed group. It can be specified when the style number of the DX or MV is greater than or equal to 2.

**Circular display setting (DX200C Only)**

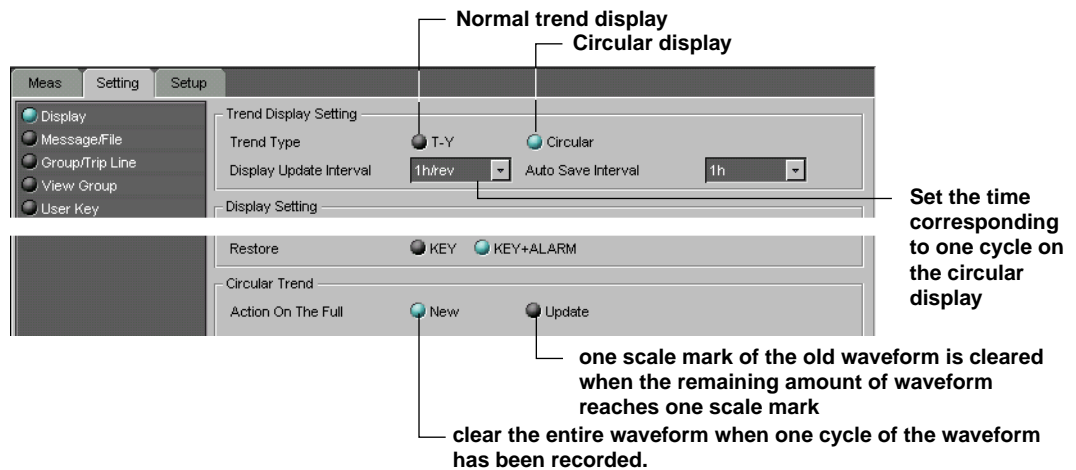

**Message/File**

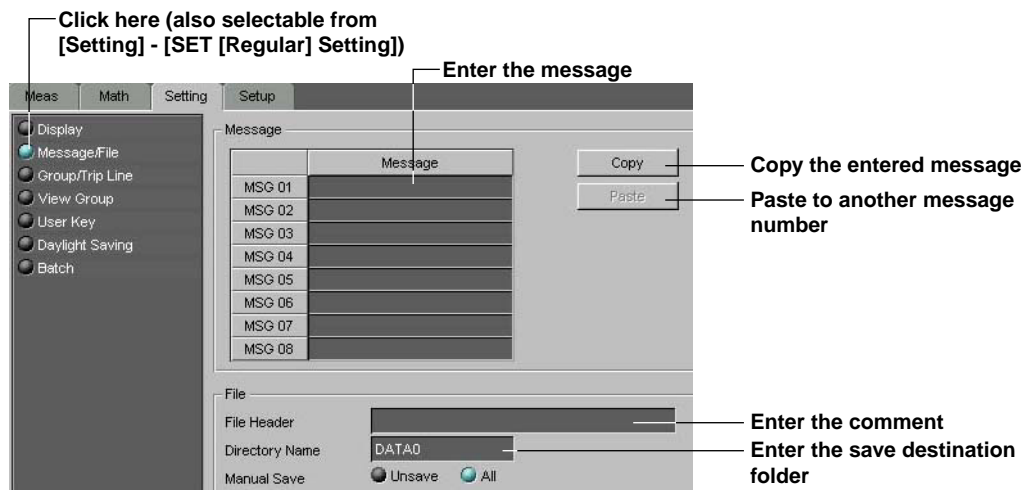

**Message**

Up to 16 characters can be entered for the message.

**File header**

Adds a comment to the header section of the measurement/computation data file.

**Director name**

Set the name of the folder in which the measurement/computation data files is to be saved.

**Note**

- Up to eight characters can be entered for the file header and director name. AUX, CON, PRN, NUL, and CLOCK cannot be used.
- If the directory name is not specified, DATA0 (default) is automatically set.

**Manual save**

Select whether to save all the data or data that have not been saved during manual save.

### 3.4 Configuring the Settings

#### Group/Trip Line

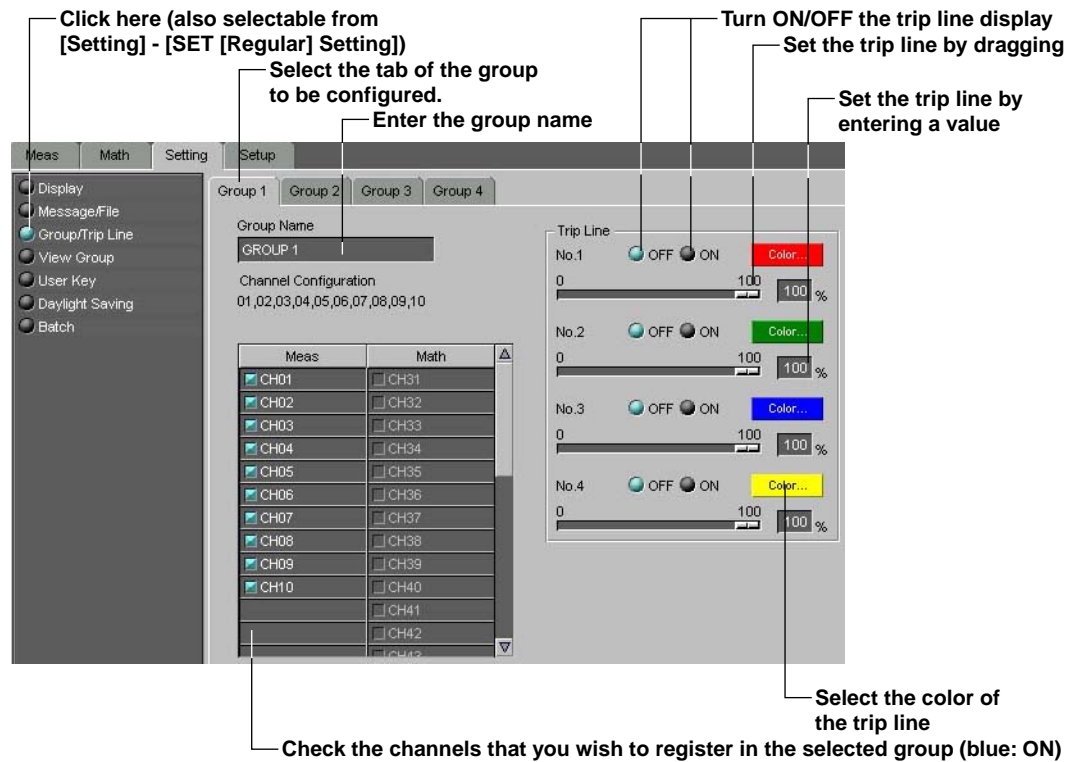

#### Group name

Up to 16 characters can be entered for the group name.

#### Number of channels

The maximum number of channels that can be assigned to a group is 10 and 6 for DX200/DX200C/MV200 and DX100/MV100, respectively. The assigned channels are listed under [Channel Configuration].

If no channels are specified, CH01 is automatically assigned.

#### Trip line

Up to four trip lines can be set to one group.

With regard to the trip lines set here, the first and second settings (No.1 and No. 2) refer to the trip lines in the Data Monitor and Data Viewer. If you change them here, they will also change in the Data Monitor and Data Viewer.

### Setting the View Group (DX200, DX200C, MV200 Only)

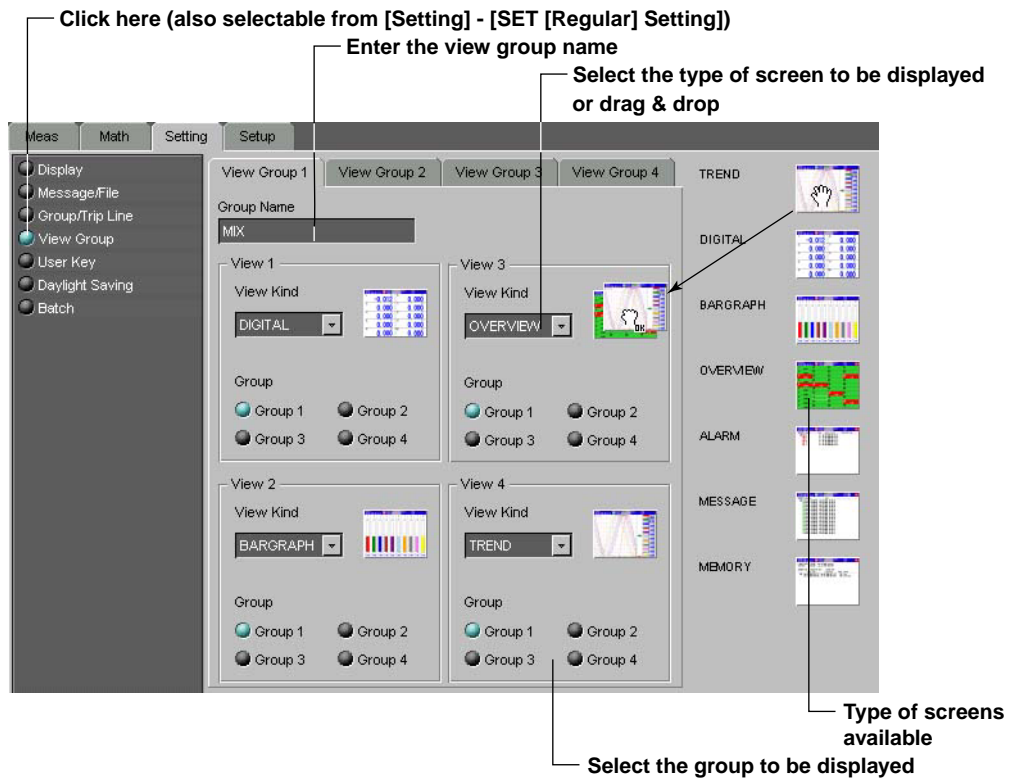

#### View group

Up to four view groups can be registered.

#### Group Name

Up to 16 characters can be entered for the group name. The specified group name appears as a sub menu of the [4 Panel] display of the DX200/MV200.

#### Screen type

The view group is made up of four screens. Select the type of screen to display in each screen.

### USER Key (DX100, DX200, DX200C, and MV200 Only), Daylight Saving, Batch (Option, When the Style Number is Greater than or Equal to 2)

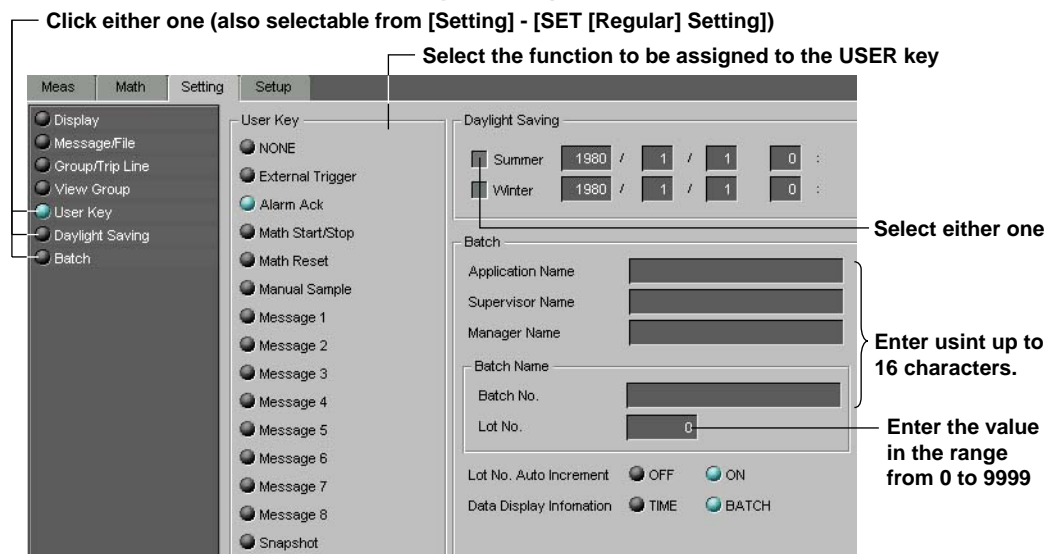

## 3.5 Configuring the Setup Mode

### Alarm/Relay/Remote

2. Click here (also selectable from [Setting] - [SETUP [Basic] Setting]-[Setting])

1. Select this tab

Select from 1 to 15 times

Copy/Paste the selected range

Select the controlled item

|          | Action |
|----------|--------|
| REMOTE 1 | NONE   |
| REMOTE 2 | NONE   |
| REMOTE 3 | NONE   |
| REMOTE 4 | NONE   |
| REMOTE 5 | NONE   |
| REMOTE 6 | NONE   |
| REMOTE 7 | NONE   |
| REMOTE 8 | NONE   |

#### Alarm

Select the alarm format. The selected items become blue.

#### Relay AND

Set the range of relays (from the first alarm relay) to take the AND logic. All other relays will be set to OR logic. If [NONE] is selected, all relays will operate using the OR logic.

#### Remote (Option)

You can assign items to be controlled by the eight remote control terminals. This is possible, if the remote function is available.

For details related to the copy/paste function, see page 3-7.

## Scan Interval/Memory

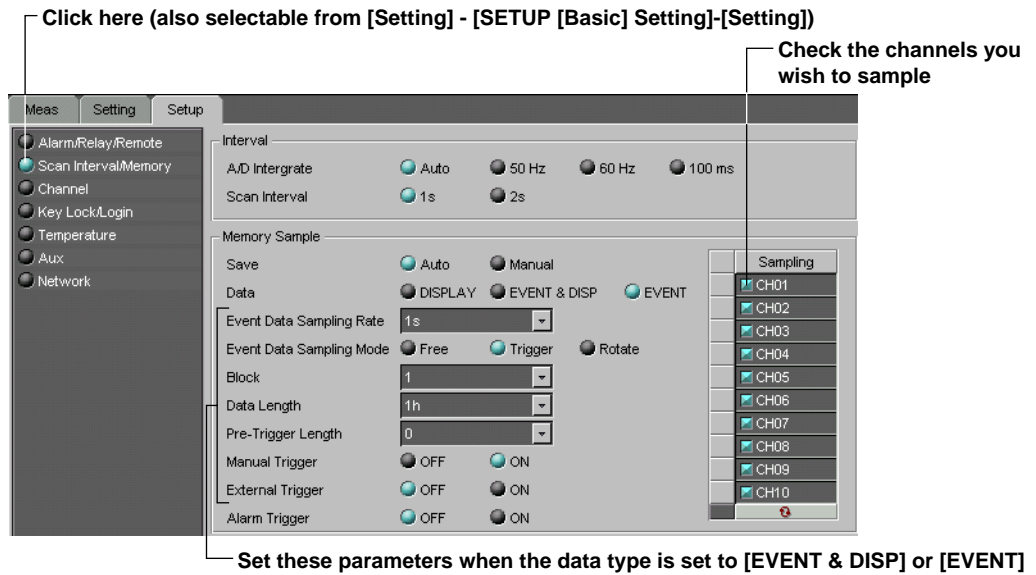

### Scan interval

The selectable scan intervals vary depending on the model as follows:

DX102, DX104, DX204, DX208, DX204C, DX208C, MV102, MV104, MV204, : 125 ms and 250 ms

DX106, DX112, DX210, DX220, DX230, MV106, MV112, MV220, and MV230: 1 s and 2 s

### A/D Integrate

100 ms can be selected only when the scan interval is set to 2 s.

### Memory Sample (save method of measured/computed data)

- Number of blocks  
When the data type is [EVENT], select 1, 2, 4, 8, or 16.  
When the data type is [EVENT&DISP], select 1, 2, or 4.
- Pre-Trigger Length  
If 0% is selected, the event file will entirely consist of data after the trigger. If 100% is selected, the event file will entirely consist of data before the trigger.
- Memory Sample  
Select the channels that are to be saved to the memory.

### Note

If [Save] is set to [Manual], the data directory is created at a location that cannot be managed by the DAQ Desktop. Therefore, the DAQ Desktop cannot be used to handle data files in that directory.

### 3.5 Configuring the Setup Mode

#### Channel (Setting the Burnout and RJC)

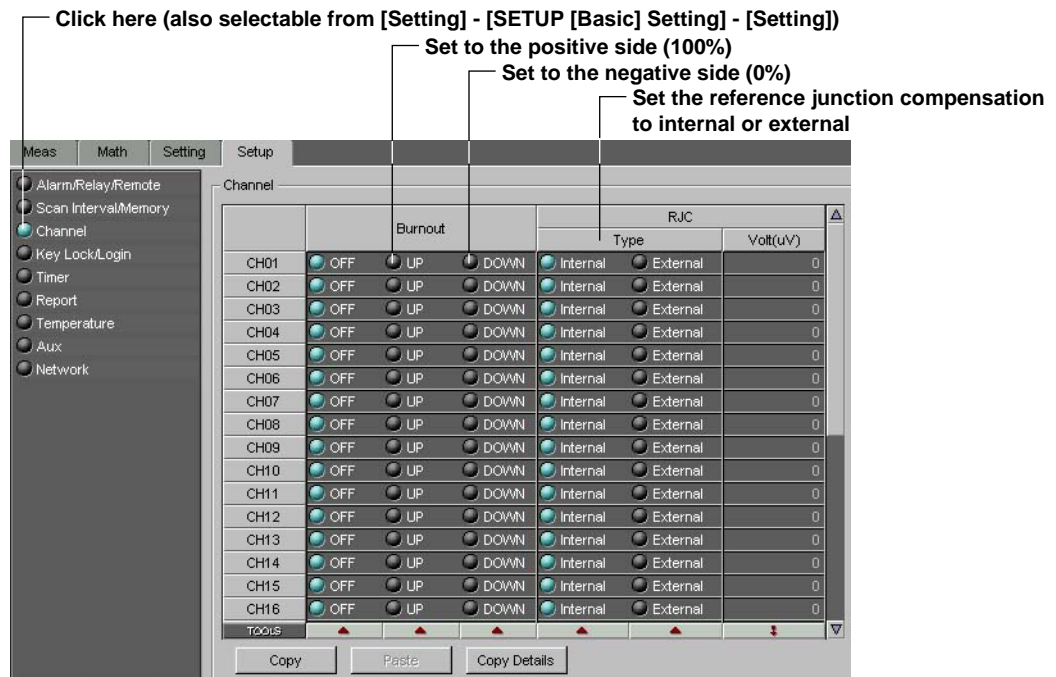

#### Burnout

For thermocouple (TC) inputs, select how the measurement results are to be handled when the thermocouple burns out.

#### RJC Volt (uV)

When the reference junction compensation is set to [External], set the compensation value in the range from -20,000 to 20,000.

#### Copying and pasting setup data

The items checked in [Copy Details] can be copied and pasted. Click the channel number to select the copy source or paste destination.

To select multiple channels to be copied, drag the channel number to specify the range to be copied. To select multiple copy destinations, select the range in a similar fashion.

### Key Lock/Login

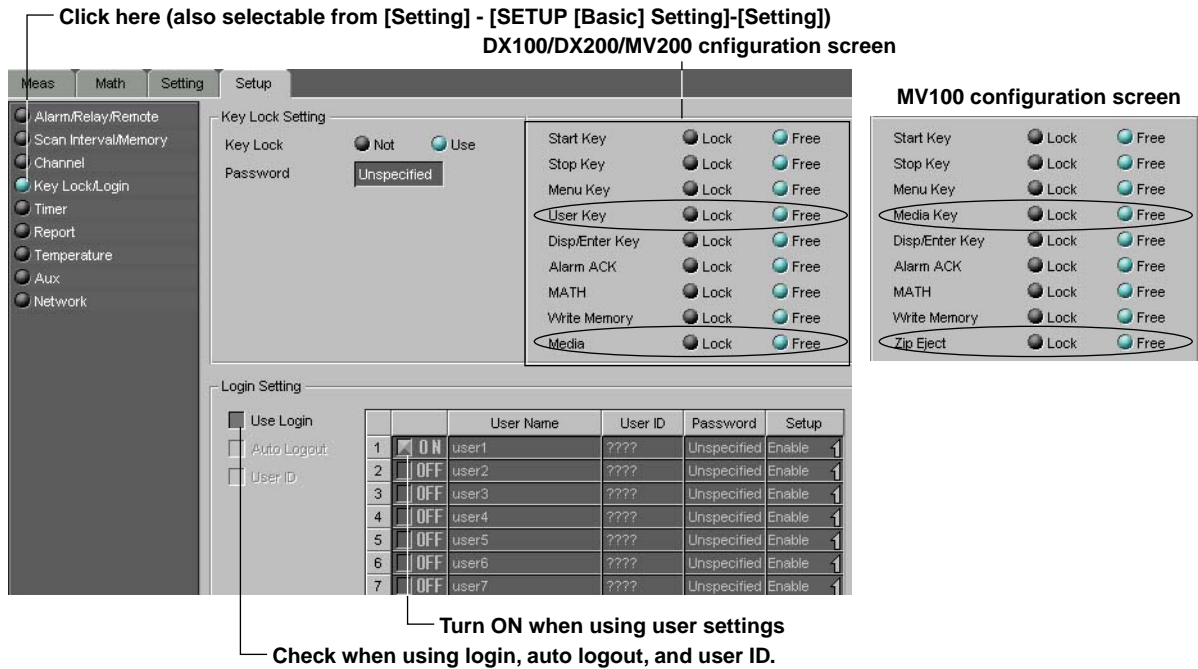

#### Setting the key lock

- **Key Lock**

When using the key lock function, select whether or not to activate the key lock function (lock or free).

- **Password**

Enter the password used to release the key lock using up to six characters. [???] is displayed after the password is entered.

#### Setting the login

- **User name**

Up to 16 characters can be entered for the user name.

- **User ID**

Up to 4 characters can be entered for the User ID. [???] is displayed after the password is entered.

- **Password**

Up to 6 characters can be entered for the password. [???] is displayed after the password is entered.

- **Setup**

Select whether or not to allow setting changes in the setup mode.

#### Note

- If there is a duplicate [User Name] that is turned ON, the user with the larger user number is turned OFF.
- If [Setup] of all users that are turned ON is set to [Disable], the [Setup] of the user with the smallest number is set to [Enable].



### 3.5 Configuring the Setup Mode

#### Timer (Option)

The screenshot shows the 'Setup' mode interface with a sidebar on the left containing menu items: Alarm/Relay/Remote, Scan Interval/Memory, Channel, Key Lock/Login, Timer (highlighted), Report, Temperature, Aux, and Network. The main area displays three timer configuration panels: Timer 1, Timer 2, and Timer 3. Each panel includes a status indicator (OFF, Absolute, or Relative), an Interval dropdown menu (set to 1h), a Ref.time field (set to 0:00), and checkboxes for Reset and Save Data. Annotations with arrows point to specific elements: 'Click here (also selectable from [Setting] - [SETUP [Basic] Setting]-[Setting])' points to the 'Timer' menu item; 'Select one' points to the radio buttons for Absolute and Relative; 'Timeout every time the specified time elapses' and 'Select the timeout time' point to the Interval dropdown; 'Time out with the specified time as the reference' points to the Ref.time field; 'Reset computation when a timeout occurs' points to the Reset checkbox; and 'Save the data to the TLOG file when a timeout occurs.' points to the Save Data checkbox.

You can set three types of timers to be used in the statistical computation. You can have the data saved to a TLOG file or reset the computation when the specified timeout time elapses.

### Report (Creating Hourly/Daily/Weekly/Monthly Reports)

Click here (also selectable from [Setting] - [SETUP [Basic] Setting]-[Setting])

Set the date and time at which to create the report

Select the channel to be reported

Enable (ON)/Disable (OFF) the report channel settings

#### Report channel

There are 30 channels and 12 channels on the DX200/DX200C/MV200 and DX100/MV100, respectively.

#### Converting the reference unit time

Select whether or not to convert the computed results of the TLOG.SUM computation channels to a specified time unit value. Select [Off (no conversion)], [Sec (seconds)], [Min (minutes)], or [Hour (hours)].

#### Copy

For details related to the copy/paste function, see page 3-7.

3 Configuring the DX100/DX200/DX200C/MV100/MV200

## Setting the Temperature, Tag, Memory Alarm Time, Displayed Language, and Partial Expanded Display

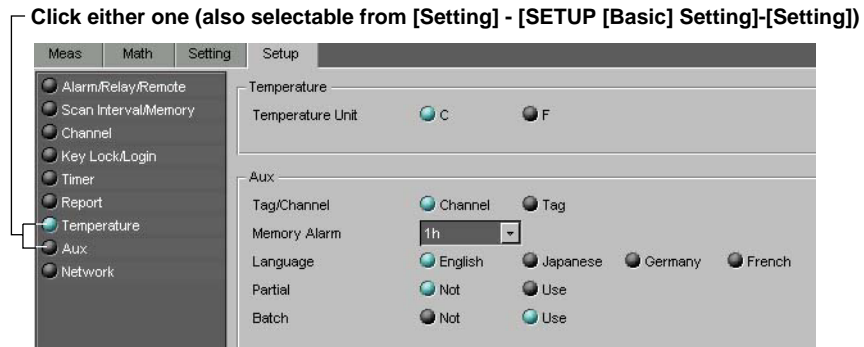

### Temperature

Select the °C or °F for the temperature unit.

### Tag/Channel

Select whether to use the tag name or channel number as the measurement/computation channel label (See “Selecting the Characters Used to Identify Channels” on page 3-6). If you select tag name, you can select the label display from tag and channel.

### Memory alarm time

Free space in the internal memory is monitored, and the memory full relay can be programmed to activate some period of time before the memory is completely full. This time period is called the memory alarm time.

### Displayed language

Select the language to be used on the display.

The types of displayed language vary depending on the style number of the DX or MV. If the style number is greater than or equal to 2, you can select German or French in addition to English and Japanese.

### Partial expanded display

If the partial expanded display is set to [Not], the partial expanded display settings of the Meas/Math tab are void.

### Batch function (option)

You can set the batch function when the style number of the DX or MV is greater than or equal to 2.

Network

Setting the TCP/IP

1. Click here (also selectable from [Setting] - [SETUP [Basic] Setting]-[Comm])

2. Select this tab

Set the IP address

Set these addresses when using the DNS

Enter the timeout value when turned ON

In the case of a CONFIG file, the IP address cannot be configured. When communicating with the DX100/DX200/MV100/MV200 via Ethernet, the IP address, subnet mask, and default gateway must be set on the DX100/DX200/MV100/MV200 beforehand.

Setting the FTP

1. Select this tab.

2. Select the primary or secondary tab.

Select the file transfer destination

By using the FTP function, you can automatically transfer the measured/computed data files to the specified server.

### 3.5 Configuring the Setup Mode

#### Setting the serial communication



## 3.6 Adjusting the Setup Data (Checking the Data)

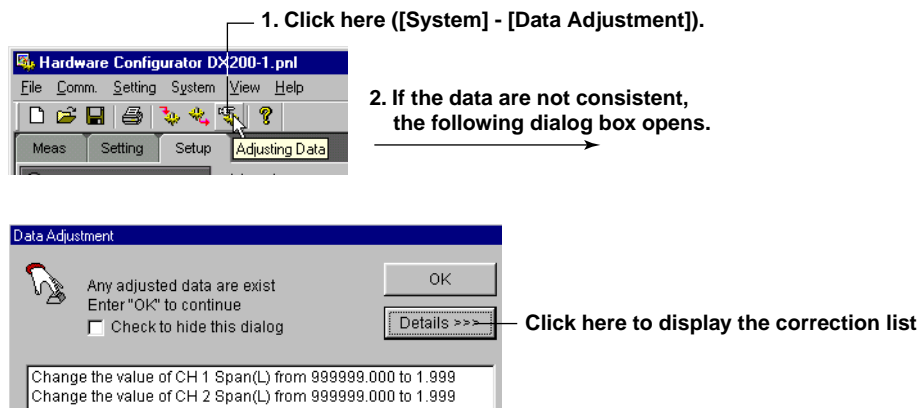

Checks whether or not the specified setup is consistent with the actual system. If it is not, the data are automatically corrected.

The data are corrected in the following cases:

- When the values of the items of the Meas/Math tab are outside the range.
- When an invalid character string is used

### Data adjustment dialog box

If [View] - [Data Adjustment Dialog Box] is checked, the [Data Adjustment] dialog box will open when the data are not consistent at the time of the data check or at the time of data transmission.

### Note

Perform the data check before sending the new setup data to the DX100/DX200/MV100/MV200.

---

## 3.7 Sending the Setup Data to the DX/MV

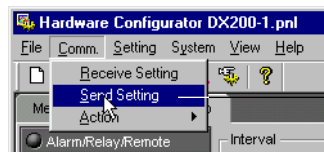

The setup data are sent when [Comm] - [Send] is selected.

A confirmation dialog box is displayed.

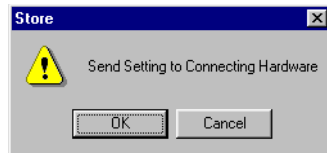

To send the new setup data to the DX100/DX200/DX200C/MV100/MV200, click the [OK] button. If the DX100/DX200/DX200C/MV100/MV200 is acquiring data to the memory, a message "Now Memory & Math sampling. Can't store setting" is displayed. The data will not be sent in this case.

### Note

Of the network settings in the [Setup] tab, the following items are not transmitted.

- [IP Address] under the [TCP/IP] tab
  - All settings under the [Serial] tab
-

# 3.8 Checking the System Configuration and Initializing Setup Data

## Checking the System Configuration

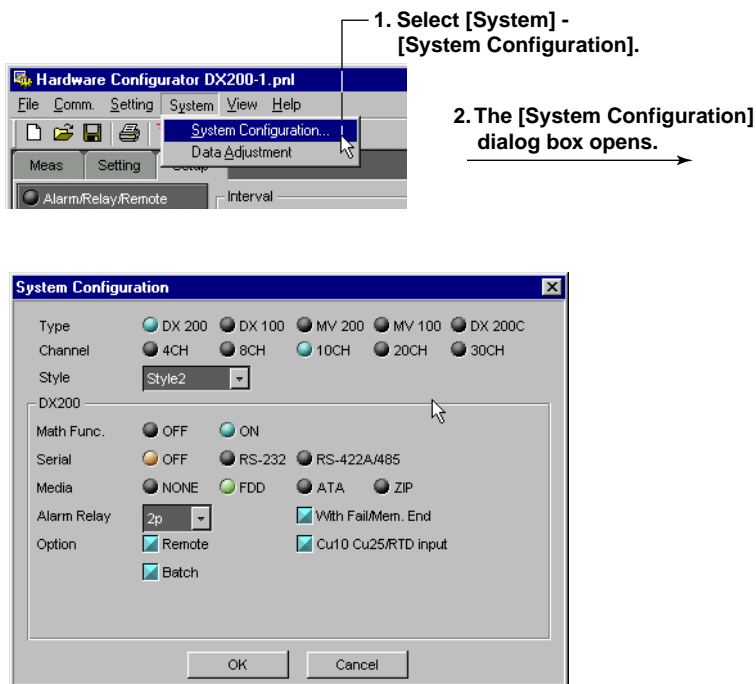

Only the system configuration in the setup data file can be checked. If the system configuration is changed and the [OK] button is clicked, a message “System Configuration is changed Input & Data are Initialized” appears. Clicking the [OK] button initializes the data.

## Initializing the Setup Data

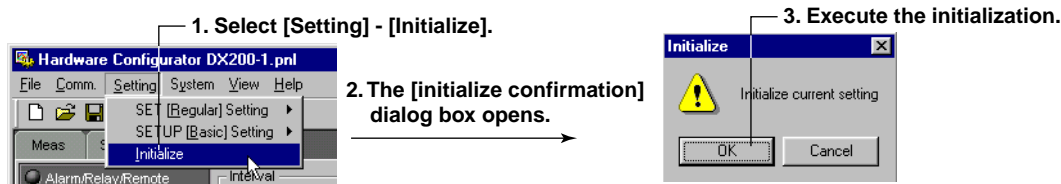



## 3.9 Saving the Setup Data

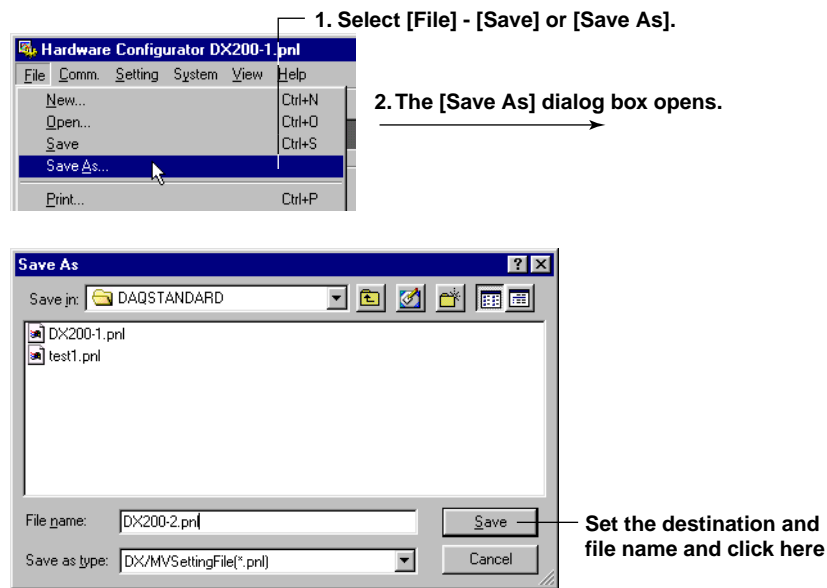

### Save

The setup data are overwritten to the preexisting file (\*.pnl). The [Save As] dialog box does not open.

### Save As

Saves the setup data by specifying the save destination and file name.

# 3.10 Printing the Setup Data

## Setting the Printer

1. Select [File] - [Print Setup].

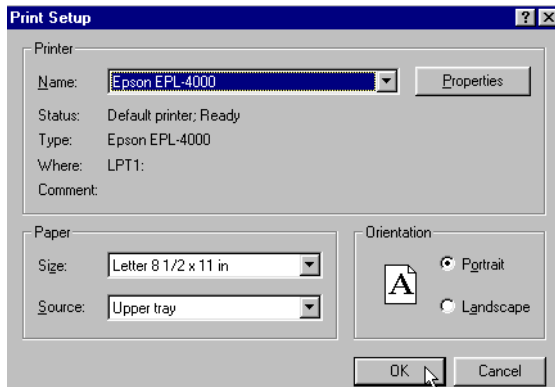

2. Set the printer, paper and orientation.

### Note

Set the printer according to the environment of the system that you are using.

## Print Preview

You can preview the print layout before actually printing the data. Selecting [File] - [Print Preview] displays the print preview screen.

## Printing

1. Click here ([File] - [Print]).



2. The [Print] dialog box opens.

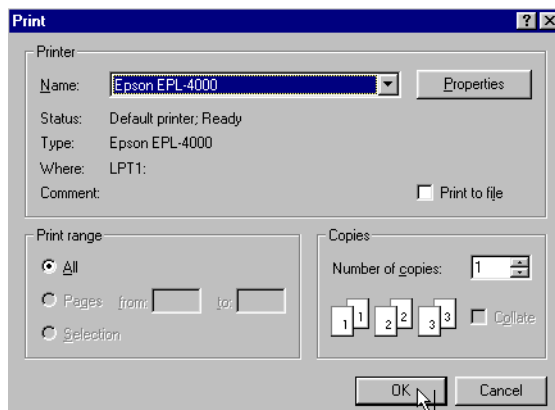

Select the printer, print range, the number of copies, and click the [OK] button

## 3.11 Starting and Stopping Measurement on the DX/MV, Checking the DX/MV System Configuration

From this software you can start and stop the DX/MV, and display DX/MV system configuration information.

### Starting and Stopping Measurement

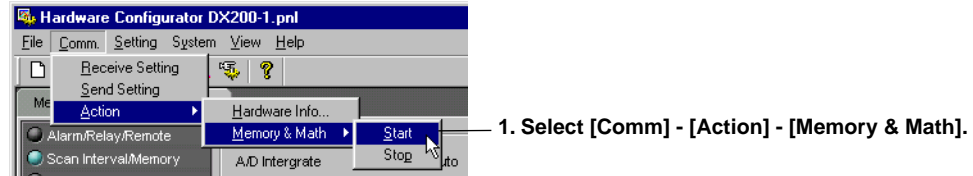

### Display DX/MV system configuration information

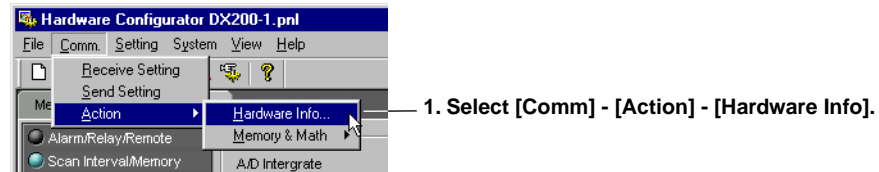

## 3.12 Characters that can be Used

The characters in the following table can be used when entering a group name, a view group name, a message, a comment to the file header, a save destination directory name, the password for the key lock function, and login parameters such as the user name, user ID, and password.

|    |   |   |   |   |   |   |   |   |   |
|----|---|---|---|---|---|---|---|---|---|
| SP | # | % | ( | ) | * | + | - | . | / |
| 0  | 1 | 2 | 3 | 4 | 5 | 6 | 7 | 8 | 9 |
| A  | B | C | D | E | F | G | H | I | J |
| K  | L | M | N | O | P | Q | R | S | T |
| U  | V | W | X | Y | Z |   |   |   |   |
| a  | b | c | d | e | f | g | h | i | j |
| k  | l | m | n | o | p | q | r | s | t |
| u  | v | w | x | y | z |   |   |   |   |
| _  | ° | @ |   |   |   |   |   |   |   |

### Note

(\*), (+), (.), and (/) cannot be used for the name of the directory where files are to be saved.

# 4.1 Starting and Exiting the Data Viewer

## Starting the Data Viewer

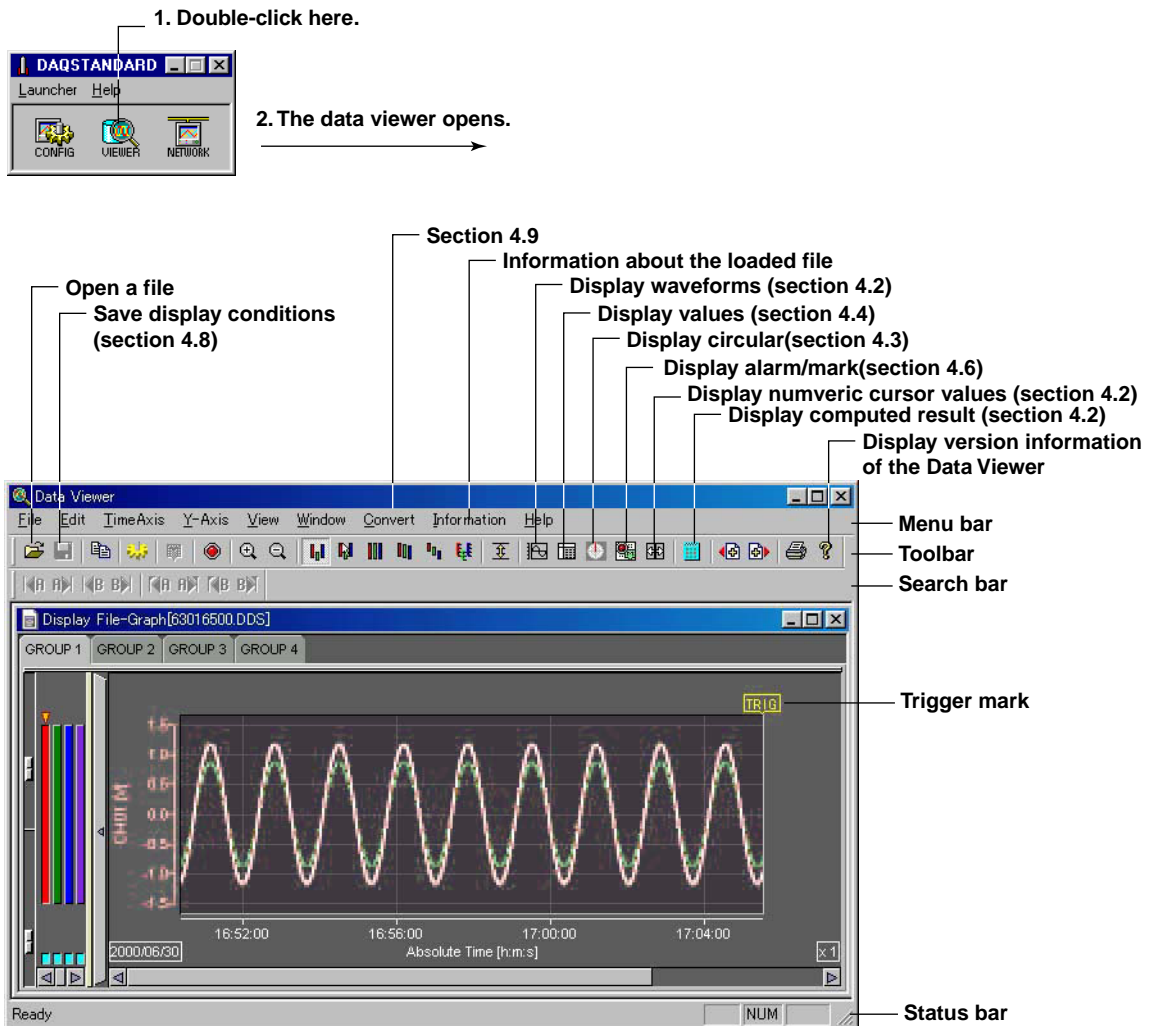

You can also start the program by selecting [Start] - [Programs] - [DAQEXPLORER] - [Viewer]. You can start multiple Data Viewers by starting the program from the Start menu.

### Files that launch the Data Viewer

- Display data file (\*.dds)
- Event data file (\*.dev)
- TLOG file (\*.dtg)
- Link setting file (\*.ldx)

### Toolbar, search bar, and status bar

Clicking [View] - [Toolbar], [Search Bar], or [Status Bar] from the menu bar displays the corresponding bar in the window. The bar will disappear if the check is removed.

### Opening the File by Specifying its Location

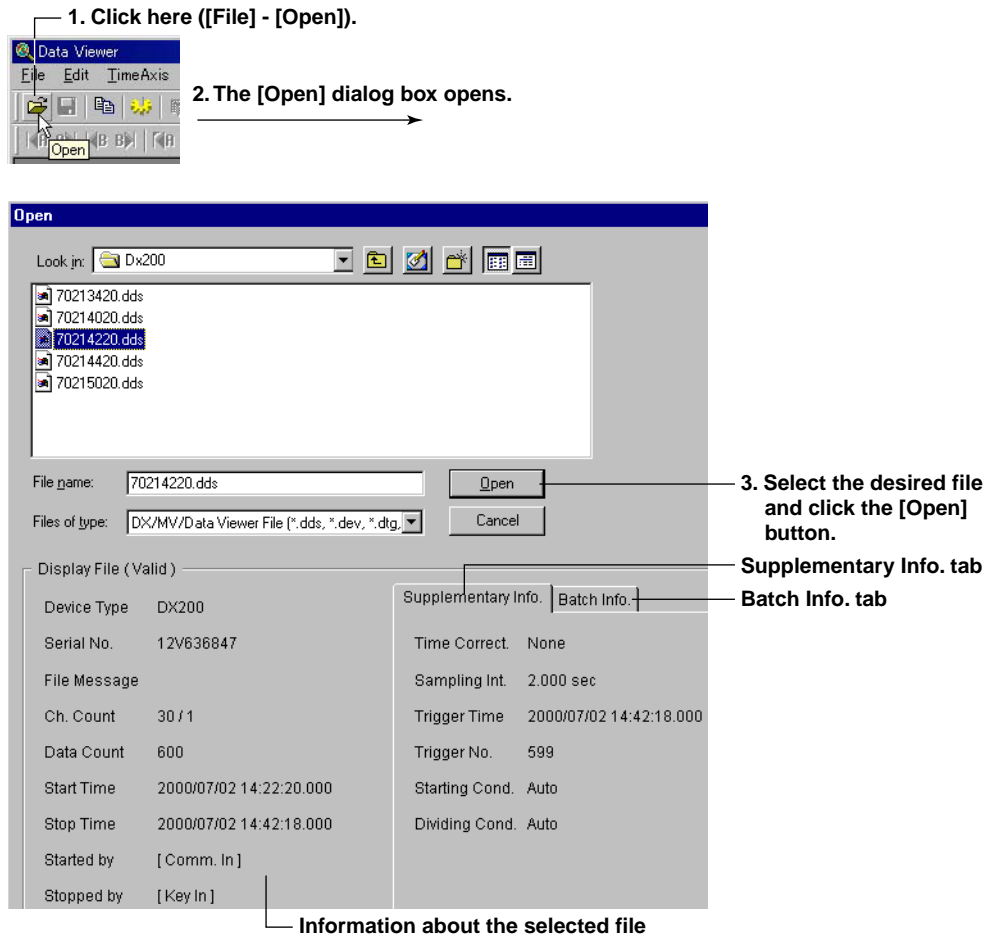

You can open a file by specifying the location.

### Checking the information about the loaded file

You can check the information about the active data file by selecting [Information] - [About Document].

- For waveform data files and event data files

| File Information                                       |                           |
|--|---------------------------|
| <input checked="" type="checkbox"/> File Name          | : Z0307430.DDS            |
| <input checked="" type="checkbox"/> Device Type        | : DX100                   |
| <input checked="" type="checkbox"/> Hardware ID        | : 12V847099               |
| <input checked="" type="checkbox"/> File Message       | : wa-----                 |
| <input checked="" type="checkbox"/> Time Correction    | : None                    |
| <input checked="" type="checkbox"/> Starting Condition | : Manual                  |
| <input checked="" type="checkbox"/> Dividing Condition | : Auto                    |
| <input checked="" type="checkbox"/> Meas Ch.           | : 4                       |
| <input checked="" type="checkbox"/> Math Ch.           | : 4                       |
| <input checked="" type="checkbox"/> Data Count         | : 1800                    |
| <input checked="" type="checkbox"/> Sampling Interval  | : 2.000 sec               |
| <input checked="" type="checkbox"/> Start Time         | : 1999/12/03 07:43:50.000 |
| <input checked="" type="checkbox"/> Stop Time          | : 1999/12/03 08:43:48.000 |
| <input checked="" type="checkbox"/> Trigger Time       | : 1999/12/03 08:43:48.000 |
| <input checked="" type="checkbox"/> Trigger No.        | : 1799                    |
| <input checked="" type="checkbox"/> Damage Check       | : Valid                   |
| <input checked="" type="checkbox"/> Started by         | : [None]                  |
| <input checked="" type="checkbox"/> Stopped by         | : [None]                  |
| <input checked="" type="checkbox"/> Comment            | : [ ]                     |
| Batch Information                                      |                           |
| <input checked="" type="checkbox"/> Application        | : [None]                  |
| <input checked="" type="checkbox"/> Supervisor         | : [None]                  |
| <input checked="" type="checkbox"/> Manager            | : [None]                  |
| <input checked="" type="checkbox"/> Batch Name         | : [None]                  |
| <input checked="" type="checkbox"/> Batch No.          | : [None]                  |
| <input checked="" type="checkbox"/> Batch Comment User | : [None]                  |
| <input checked="" type="checkbox"/> Batch Comment 1    | : [None]                  |
| <input checked="" type="checkbox"/> Batch Comment 2    | : [None]                  |
| <input checked="" type="checkbox"/> Batch Comment 3    | : [None]                  |

- For TLOG files

| File Information                                    |                           |
|---|---------------------------|
| <input checked="" type="checkbox"/> File Name       | : Z0511420                |
| <input checked="" type="checkbox"/> Device Type     | : DX100                   |
| <input checked="" type="checkbox"/> Hardware ID     | : 12V847099               |
| <input checked="" type="checkbox"/> File Message    | : wa-----                 |
| <input checked="" type="checkbox"/> Meas Ch.        | : 4                       |
| <input checked="" type="checkbox"/> Math Ch.        | : 4                       |
| <input checked="" type="checkbox"/> Interval Up     | : 1                       |
| <input checked="" type="checkbox"/> TLOG Start Time | : 1999/12/05 09:55:37.625 |
| <input checked="" type="checkbox"/> Damage Check    | : Valid                   |
| <input checked="" type="checkbox"/> Timer No.       | : 1                       |
| <input checked="" type="checkbox"/> Comment         | : [ ]                     |

The items that are checked are output in the header when printed.

### Note

- Multiple files can be opened simultaneously.
- The number of files that can be opened simultaneously depends on the memory size of the PC and the free disk space.

### Exiting the Data Viewer

Select [File] - [Exit] or click the [X] button. If you changed the settings in any of the windows, a message "Save changes to \*\*\*\*.\*\*\*?" is displayed. Click the [Yes] button, if you wish to save the settings and exit the Data Viewer. Click the [No] button, if you do not wish to save the settings and exit the Data Viewer.

## 4.2 Displaying the Waveform

### Displaying the Waveform

1. Click here ([Window] - [Graph]).

2. The waveform display screen opens.

Group selection tab (click the tab of the group you wish to display)

Mark on the active waveform

Zone display area

Show/Hide the zone display area

Waveform label (Select channel No. or tag)

Indicates the section of the waveform that is being displayed in a white frame

Display the alarm/mark list

Display the cursor value

Link the previous file

Link the next file

Color overview

Color display adjuster (turn ON/OFF the color overview display)

Trip line of the active waveform

Alarm display area

Magnification

Date

Waveform display area

Move the waveform display position (Scroll bar)

Absolute or relative time

Drag this bar to change the size of the zone display area

Turn ON/OFF waveform display

**Color overview display**

Displays marks and cursors

Displays the waveforms that have the display turned ON

The measured values of the entire data are displayed using various colors. By assigning 50 different colors from the minimum to the maximum values of the scale, the measured values are assigned to those colors.

If the data are display data, the maximum value is displayed at the top of the space allocated to a single waveform, and the minimum value is displayed at the bottom.



If you click or drag the cursor on the color overview display area, the section of the waveform is displayed in the waveform display area.

**Note**

The color overview is turned OFF as default.

**General Display Settings**

1. Click here ([View] - [General Display Settings]).

2. The [General Display Settings] dialog box opens.

3. Click the tab of the group to be configured.  
The waveform corresponding to the waveform No. that is clicked becomes active.

Enter the group name

Select normal display or exponential display

Enter the display range

Enter the display position

Show/Hide the trip line

Enter the trip line Display color

| No. | Channel | Y-Axis | Form.  | Scale    |         | Zone |     | Trip 1   | Trip 2    | Color       |
|-----|---------|--------|--------|----------|---------|------|-----|----------|-----------|-------------|
|     |         |        |        | Min      | Max     | Min  | Max |          |           |             |
| W01 | CH01    | Linear | Linear | -1.500E0 | 1.500E0 | 0    | 100 | 8.372E-1 | -1.500E0  | Red         |
| W02 | CH02    | Linear | Linear | -2.000E0 | 2.000E0 | 0    | 100 | 1.429E0  | -8.571E-1 | Green       |
| W03 | CH03    | Linear | Linear | -2.000E0 | 2.000E0 | 0    | 100 | -1.117E0 | 3.896E-1  | Blue        |
| W04 | CH04    | Linear | Linear | -2.000   | 2.000   | 0    | 100 | -1.792   | -0.857    | Purple      |
| W05 | CH05    | Linear | Linear | -2.000   | 2.000   | 0    | 100 | 0.000    | 0.000     | Orange      |
| W06 | CH06    | Linear | Linear | -2.000   | 2.000   | 0    | 100 | 0.000    | 0.000     | Yellow      |
| W07 | CH07    | Linear | Linear | -2.000   | 2.000   | 0    | 100 | 0.000    | 0.000     | Light Green |
| W08 | CH08    | Linear | Linear | -2.000   | 2.000   | 0    | 100 | 0.000    | 0.000     | Light Blue  |
| W09 | CH09    | Linear | Linear | -2.000   | 2.000   | 0    | 100 | 0.000    | 0.000     | Pink        |
| W10 | CH10    | Linear | Linear | -2.000   | 2.000   | 0    | 100 | 0.000    | 0.000     | Grey        |
| W11 | <None>  | Linear | Linear | -22.00   | 22.00   | 0    | 100 | 22.00    | -22.00    | Grey        |
| W12 | <None>  | Linear | Linear | -22.00   | 22.00   | 0    | 100 | 22.00    | -22.00    | Grey        |
| W13 | <None>  | Linear | Linear | -22.00   | 22.00   | 0    | 100 | 22.00    | -22.00    | Grey        |
| W14 | <None>  | Linear | Linear | -22.00   | 22.00   | 0    | 100 | 22.00    | -22.00    | Grey        |
| W15 | <None>  | Linear | Linear | -22.00   | 22.00   | 0    | 100 | 22.00    | -22.00    | Grey        |

Initialize

Paste the copied setup data to the active waveform number

Copy the setup data of the active waveform number

Select the items to be copied

Set the maximum and minimum values of the measured data the maximum and minimum values of the scale.

Copy the settings of the first channel in the selected range to all other channels

Show/Hide the Y-axis

Register the channel

Assign numbers to the channels in the selected range in ascending order

Activate the settings and close the dialog box

Turn ON/OFF at once

Turn ON/OFF waveform display (Blue is ON)

**Group**

A maximum of 30 groups can be set. A maximum of 32 channels can be registered in one group.

## 4.2 Displaying the Waveform

### Turn ON/OFF the display

Check the box of the waveform number to be displayed. This is synchronized to the ON/OFF button of the waveform display of the zone display area.

### Registering the channel

1. Click one.

2. The [Channel No.] dialog box opens.

3. Click one.

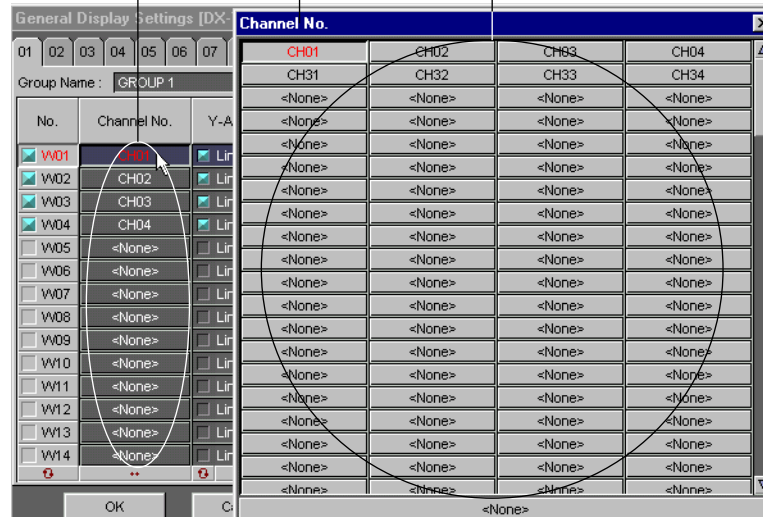

### Types of Y-axis and turning ON/OFF the Y-axis

Select linear or logarithmic by clicking the Y-axis display area. If [Multi-Axis Zone] (page 4-8, Setting the Y-axis) is selected, you can select whether or not to display the Y-axis. The Y-axis of the waveform for which the check box is shown in [blue] will be displayed.

### Scale (display range)

The range of minimum and maximum values is from  $-1.0 \times 10^{-16}$  to  $1.0 \times 10^{16}$ .

Click the scale value display area to enter values.

### Zone (display position)

The range is as follows:

- Minimum value: 0 to 99%
- Maximum value: 1 to 100%

Specify the waveform display position by taking the bottom edge of the waveform display area of the trend display screen to be 0% and the top edge to be 100%. Click the zone display area to enter values.

### Trip line

Two trip lines (trip 1 is red, trip 2 is blue) can be set for each waveform. Only the trip lines of the active waveform are displayed on the trend screen. However, on the auto zone display screen ("Setting the Y-axis" on page 4-8), the trip lines of all displayed waveforms that are checked are displayed.

You can change the position of the trip line by dragging it.

**Display color**

You can select the color of each waveform. To create custom colors, click the [Define Custom Colors] button in the [Color] dialog box.

**Copy/Paste**

The parameters that are checked in the [Copy Setting] dialog box, that opens when the [Copy Setting] button is clicked, are copied.

When the [Copy] button is clicked, the settings of the waveform corresponding to the waveform No. that was activated (displayed in red) are copied. When the [Paste] button is clicked, the settings are copied to the waveform corresponding to the waveform No. that was activated.

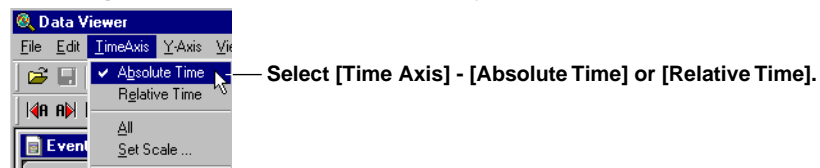
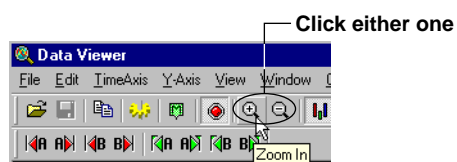
**Setting the Time Axis****Selecting absolute or relative time display****Zoom in or zoom out on the time axis**

By selecting [Time Axis] - [All], the time axis is adjusted so that all the data can be displayed. If you wish to zoom in or out by specifying the zoom rate, take the following steps (resolution is 1/1000 to 20):

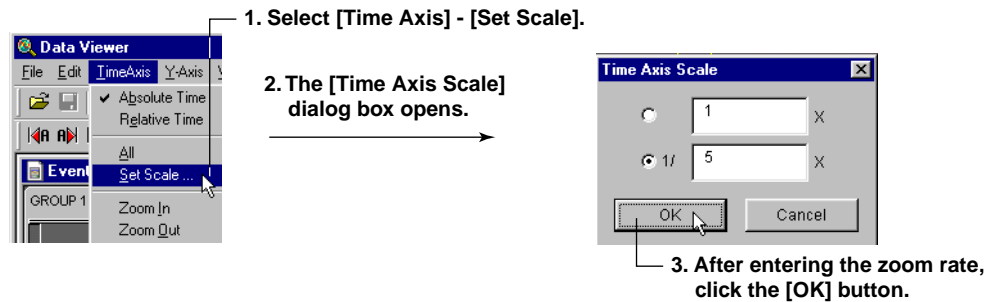

Setting the Y-axis

Selecting the waveform display zone

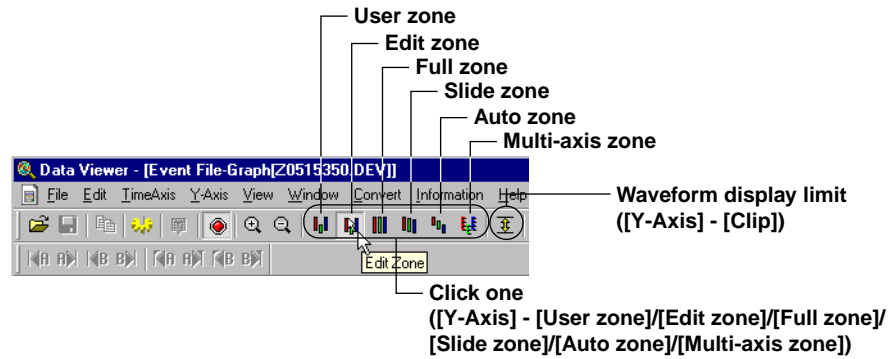

Select from the following list of choices:

For the display examples of each zone, see the next page.

- User zone: Each waveform is displayed in the range specified in [Zone] under the [General Display Setting] (the zone cannot be changed on the trend display screen).
- Edit zone: Each waveform is displayed in the range specified in [Zone] under the [General Display Setting] (the zone can be changed on the trend display screen).
- Full zone: Display all waveforms using full zones.
- Slide zone: Display the waveforms in a cascade fashion from the top to the bottom of the waveform display area.
- Auto zone: Display the waveforms by equally dividing the waveform display area by the number of displayed waveforms.
- Multi-axis zone: Display the Y-axis of multiple waveforms.

**Note**

If the waveform display zone is set to some setting other than multi-axis zone and auto zone, only the Y-axis of the active waveform is displayed.

Examples of the Various Zone Settings

- Full zone

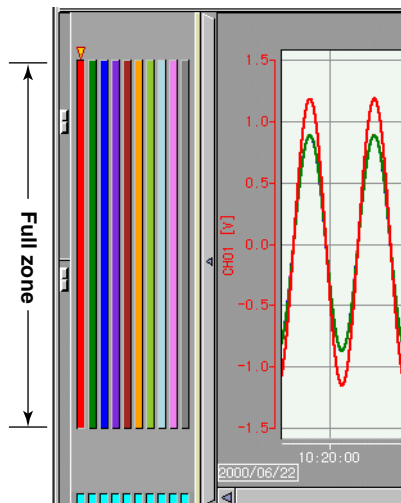

- Slide zone

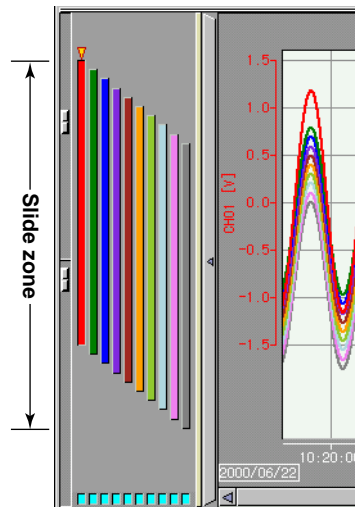

- Auto zone

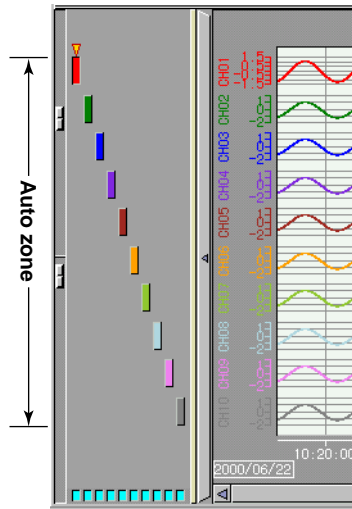

- Multi-axis zone

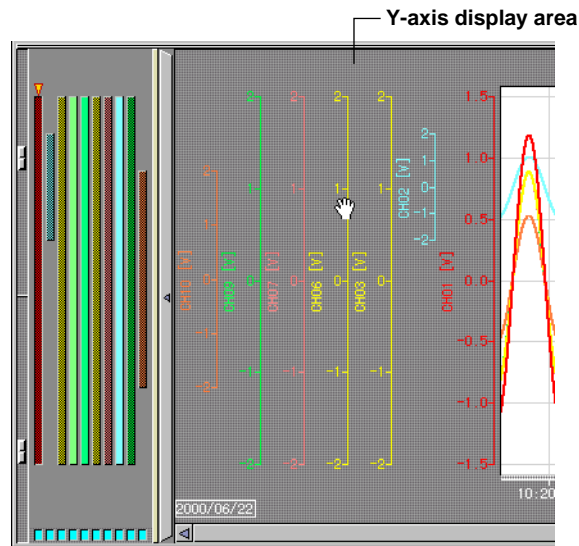

**Editing zones**

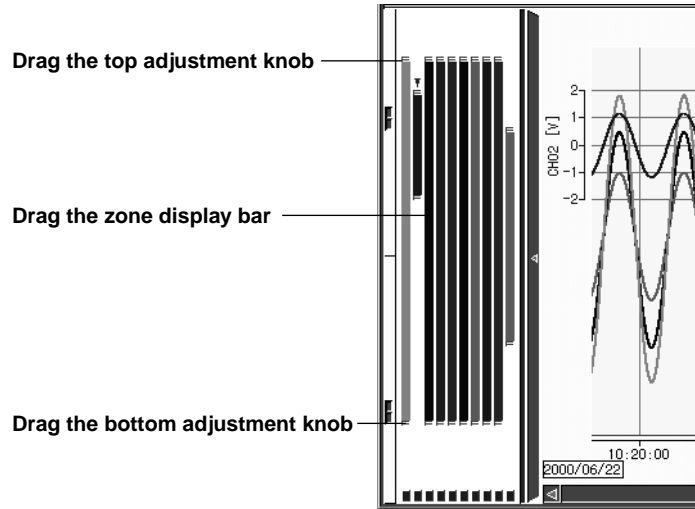

## 4.2 Displaying the Waveform

You can change the waveform display zone on the trend display screen by clicking the edit zone icon or by selecting [Y-Axis] - [Edit Zone].

The size of the zone can be changed by dragging the top and bottom adjustment knobs. The entire zone can be moved by dragging the zone display bar.

The zones that are set in [Edit Zone] are reflected in the [Zone] setting of the [General Display Settings].

### Displaying multiple Y-axis

When multi-axis zone is selected, the Y-axis scales corresponding to the [Y-Axis] boxes in the [General Display Settings] that are checked will be displayed.

- Adding a Y-axis

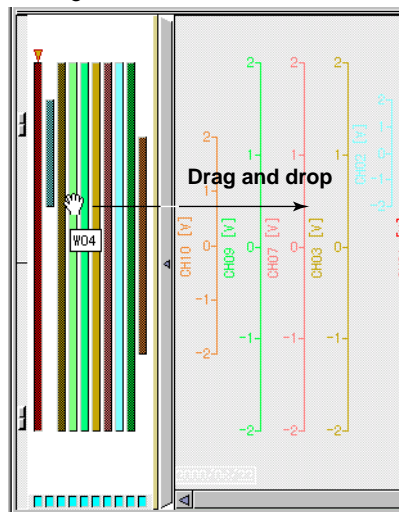

- Deleting a Y-axis

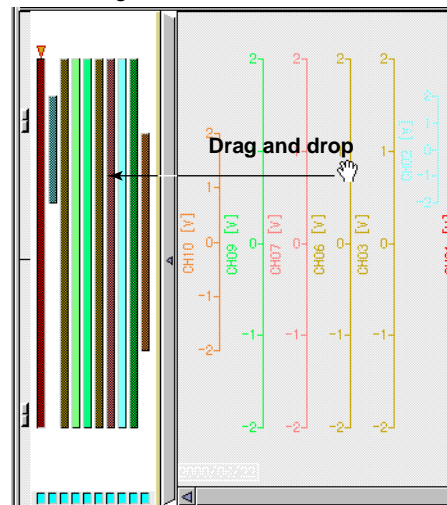

### Waveform display limit (clip)

When the waveform display limit is enabled by clicking the clip icon or by selecting [Y-Axis] - [Clip], the Y-axis display range of the waveform are limited to the minimum and maximum values that were specified under [General Display Settings] - [Scale]. Measured values that are less than the minimum value are set to the minimum value and values that are greater than the maximum value are set to the maximum value.

- Example in which Display Limit is Enabled

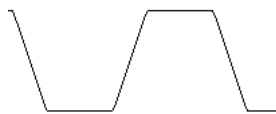

- Example in which Display Limit is Disabled



## Turn ON/OFF the Alarm Display

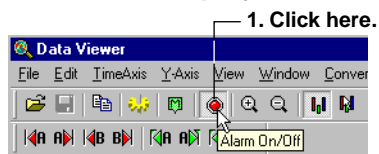

2. The alarm conditions of alarm 1 to 4 are displayed in the alarm display area.

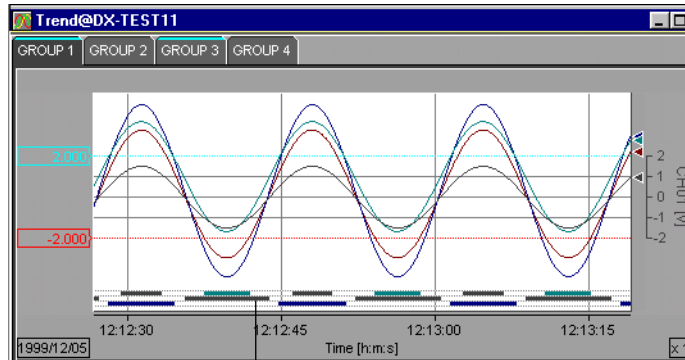

2. The alarm is displayed.

### Alarm display

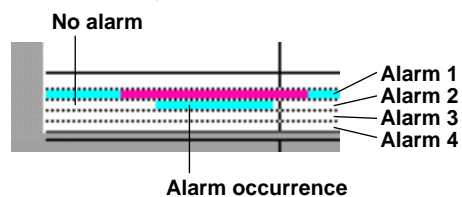

The alarm of the active waveform is displayed in front.

## Selecting the Characters Used to Identify Channels

You can select the channel No. or tag as the character string used to identify the channels by selecting [View] - [Channel No.] or [Tag]. The selected character string will be used as a label to indicate the waveform name.

The character string is registered on the DX100/DX200/DX200C/MV100/MV200 or by using the Configurator.

### Note

- When the identification string is switched, the channel character string displayed on the Y-axis of the waveform display window, circular display window, numeric window, list display window, [Cursor Value] window, [Computed Result] window, [General Display Setting] window, and data conversion dialog box will change accordingly.
- Both the channel No. and tag are used in the output result of the data conversion.

### Showing/Hiding Cursors

#### Showing the cursor

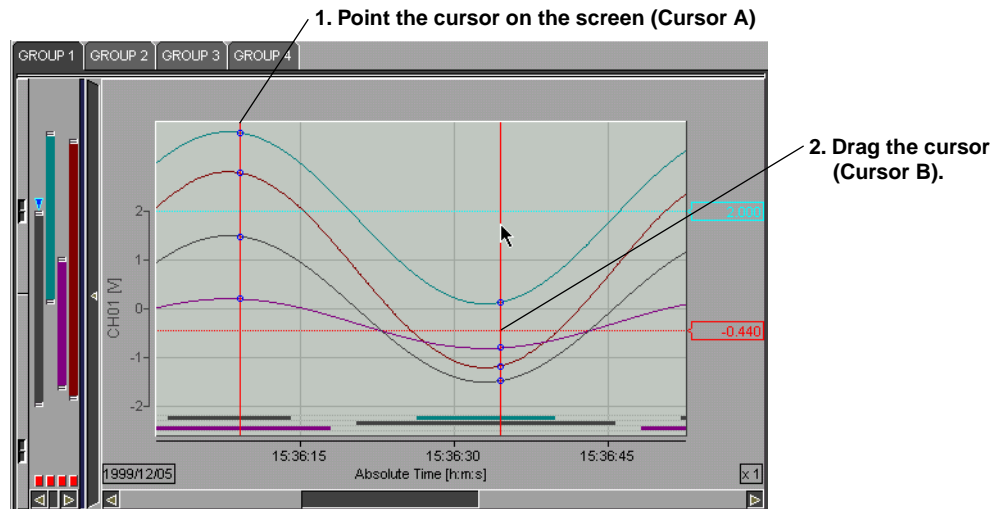

By selecting [Edit] - [Select All], Cursor A and Cursor B moves to the beginning and the end of the data, respectively.

#### Hiding the cursor

Select [View] - [Hide Cursor].

#### Copying the data to the clipboard



On the numerical window and list display window (section 4.6), you can copy the data between Cursor A and Cursor B to the Windows clipboard. On the waveform display window and circular display window, the displayed image can be copied to the clipboard.

#### Note

- The maximum number of data points that can be copied to the clipboard is 1000.
- The channels that are copied to the clipboard are those that are registered in the selected group with the waveform display turned ON.
- When the display mode of the time axis is set to absolute time, the absolute time is output. If it is set to relative time, the relative time from the first data point is output.
- Contents that have been copied to the clipboard can be pasted to other applications for use.



### Displaying Cursor's Values

Clicking the control icon or selecting [Window] - [Control] displays the [Control] dialog box.

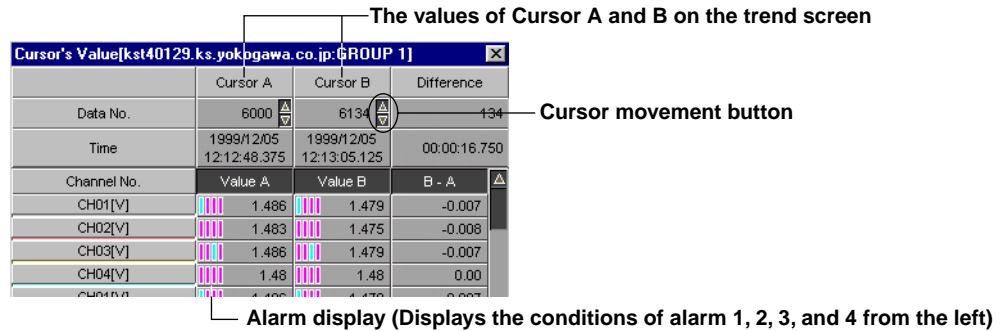
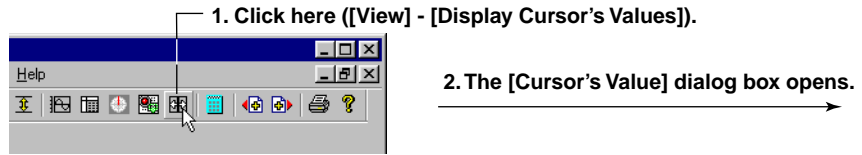

A list of Cursor A and B values and their differences on the trend screen is displayed. You can change the values of Cursor A and B by clicking the cursor movement buttons.

When the alarm display is turned ON, the alarm conditions are displayed. When an alarm is in effect, the indicator is red. When it is not, the indicator is green.

### Displaying numeric values of abnormal data

The abnormal data are displayed as follows:

- +OVER: Measured/computed data are over the positive limit
- OVER: Measured/computed data are under the negative limit
- LACK: Computation error or data dropout

### Note

When a cursor is not displayed on the trend screen, the cursor's value display area becomes blank.

### Displaying Statistics

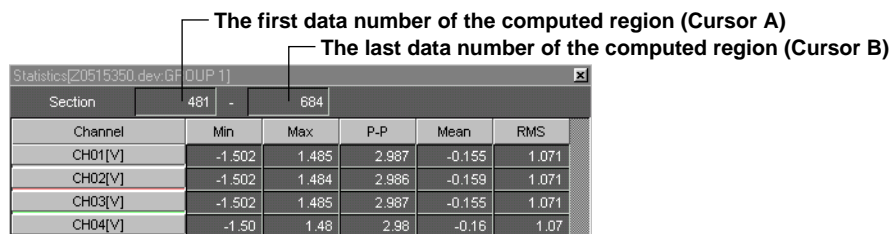
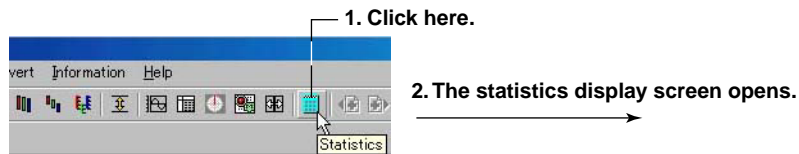

The minimum value, maximum value, P-P, mean, and rms value for each waveform in the range specified by Cursors A and B are computed and displayed. If the cursor is not displayed, the computation is performed over the entire data.

## 4.2 Displaying the Waveform

### Adding Arbitrary Marks

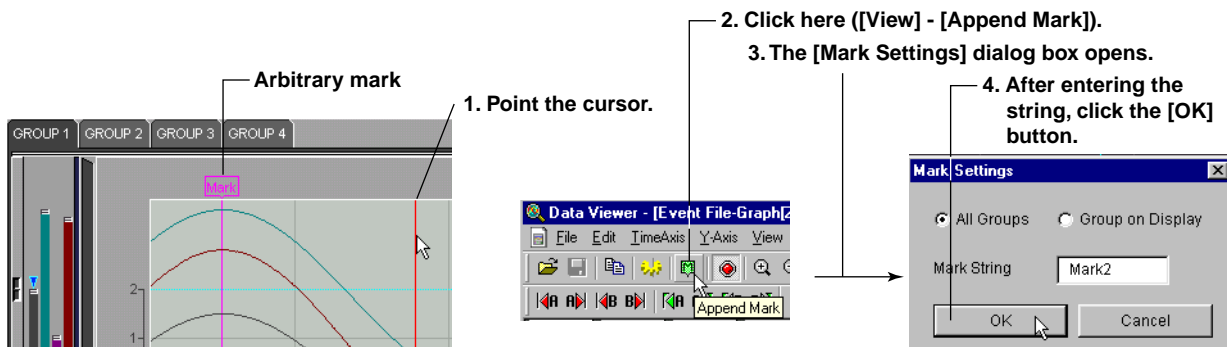

When Cursor A and Cursor B are at the same position, arbitrary marks can be placed. You can select whether to put the arbitrary marks on all groups or only on the displayed group. In addition, double-clicking a mark, that has been created using the Data Viewer, opens the [Mark] dialog box in which you can change the displayed group and the mark name.

### Searching the Alarm Transition Point and Mark Position

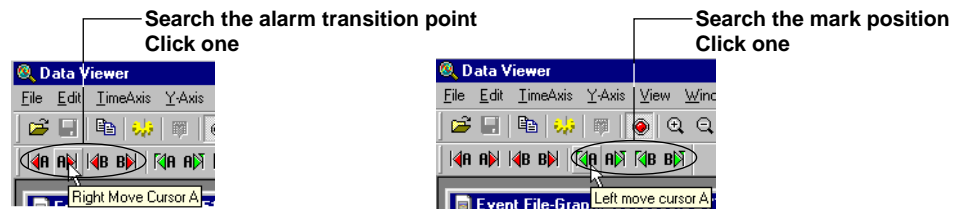

#### Searching the alarm transition point

Moves Cursor A or Cursor B to the alarm transition point (the point at which the alarm occurred and the point at which the alarm was released) of the active channel.

Searching is possible to the left and right of the cursor.

#### Searching the mark position

Moves Cursor A or Cursor B to the mark position (arbitrary mark or trigger mark) of the active channel.

Searching is possible to the left and right of the cursor.

#### Note

- The searching function cannot be used, if the cursor is not displayed.
- The search function cannot be used, if there are no arbitrary marks or when the alarm display is OFF.

## Deleting Marks

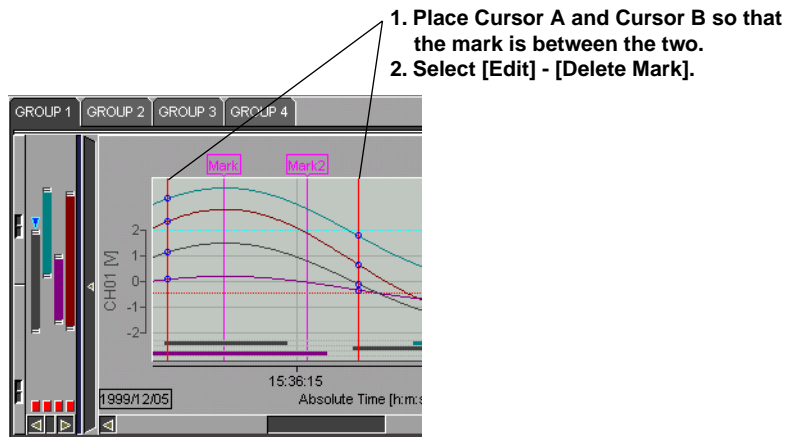

The arbitrary marks (green/yellow) and trigger marks (yellow) between Cursor A and Cursor B are deleted.

### Note

- The arbitrary marks placed on the Data Viewer are green. The arbitrary marks (messages) and trigger points placed on the DX100/DX200/DX200C/MV100/MV200 are yellow.
- Up to 16 characters can be used for a mark name.

## Resetting Marks

All arbitrary marks created on the Data Viewer are erased by selecting [Edit] - [Reset Mark]. The marks (messages) and the trigger point that were created on the DX100/DX200/DX200C/MV100/MV200 but deleted on the Data Viewer are displayed again.

## 4.2 Displaying the Waveform

### Setting the Window

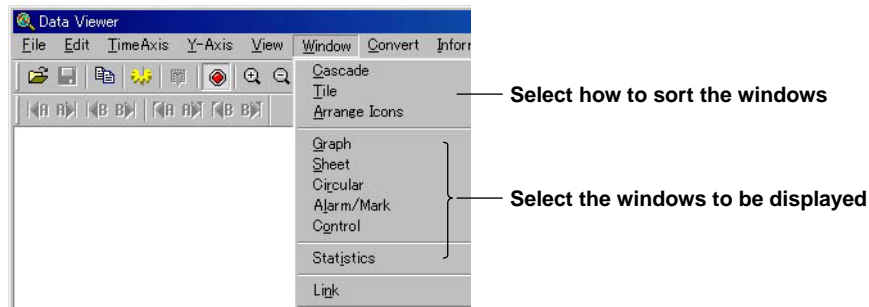

- Example of a Cascading Display

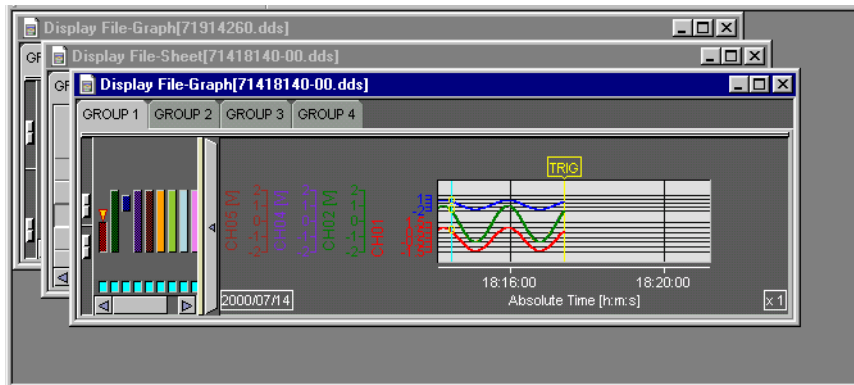

- Example of a Tiled Display

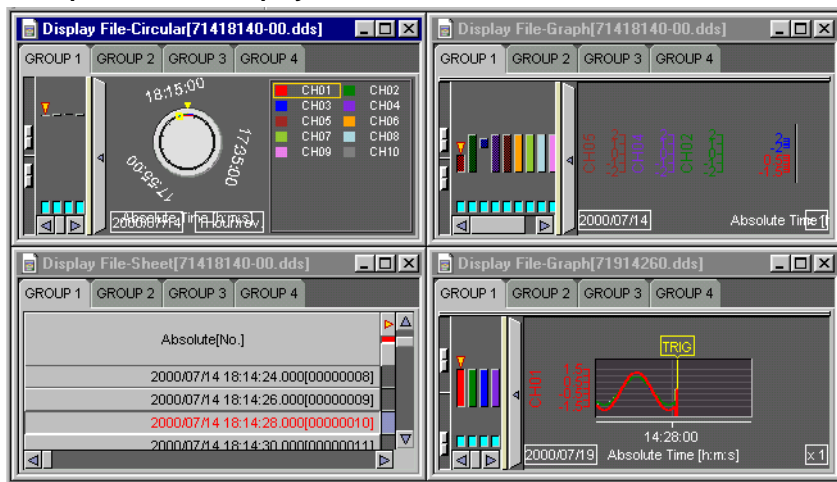

- Example of an Arranged Icon



# 4.3 Circular Display

## Circular Display

1. Click here ([Window] - [Circular]).

2. The circular display screen opens.

Group selection tab (click the tab of the group you wish to display)

Mark on the active waveform

Zone display area

Show/Hide the zone display area

Display the cursor value

Waveform label (Select channel No. or tag)

Select the active waveform

Alarm display area

Trip line of the active waveform

Displayed time per cycle

Date

Drag this bar to change the size of the zone display area

Turn ON/OFF waveform display

Circular display area

Absolute or relative time

Move the waveform display position (Scroll bar)

### General Display Settings

The parameters in the [General Display Settings] dialog box that are different between the circular display and the trend display (section 4.2) are as follows:

#### Trip line

The trip lines on the circular screen cannot be dragged and dropped.

You can change the position of the trip lines by changing the values in the [General Display Settings] dialog box.

## 4.3 Circular Display

### Setting the Time Axis

Selecting absolute or relative time display and zooming in or zooming out on the time axis  
See section 4.2, "Displaying the Waveform."

#### Selecting the displayed time

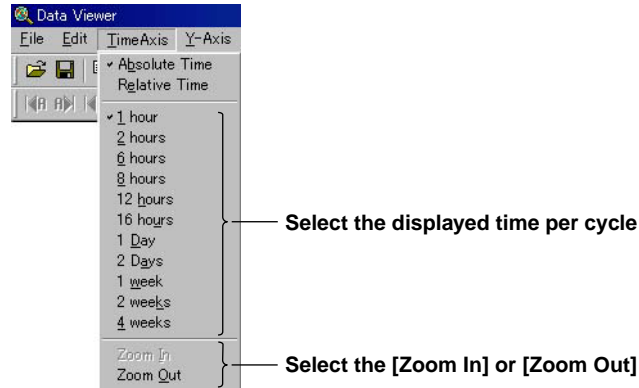

### Setting the Y-axis

The circular screen always displays the waveform that is limited to the values between the maximum and minimum values of the Y-axis display range. The range is set using [Scale] in the [General Display Settings] dialog box.

### Turning ON/OFF the Alarm Display

You can select whether to display the alarm on the inside or the outside of the waveform display section of the circular screen.

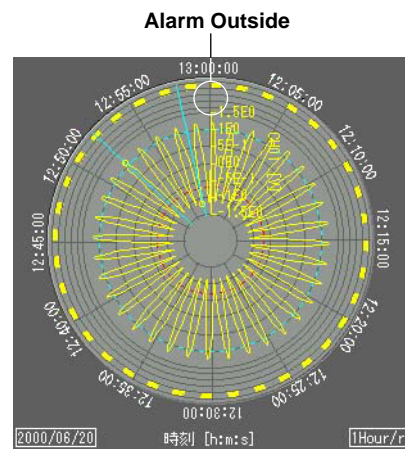
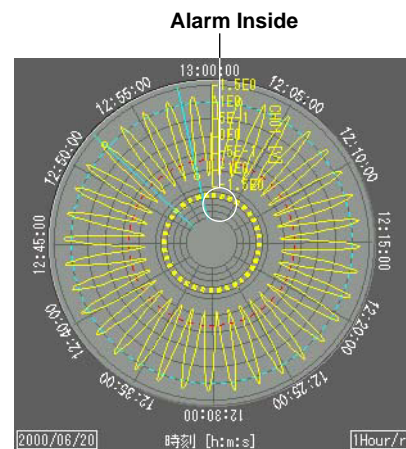
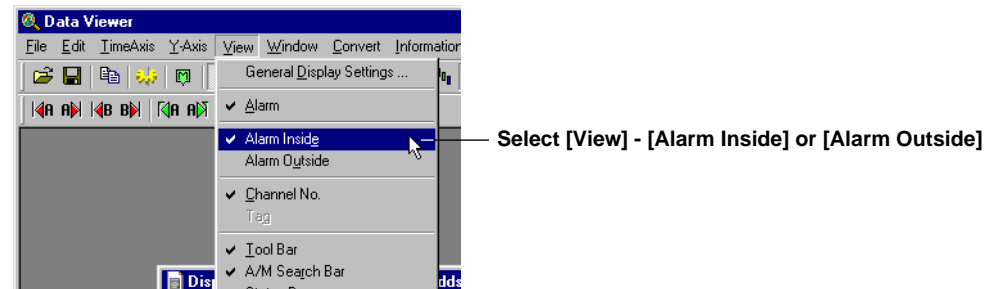

## 4.4 Displaying Numeric Values

### Displaying Numeric Values

1. Click here ([Window] - [Sheet]).

2. The numeric display screen opens.

Open a file (section 4.1)

Group selection tab (click the tab of the group you wish to display)

Save display conditions (section 4.8)

Copy to clipboard (section 4.2)

General display settings  
Section 4.2

Turn ON/OFF the alarm display  
Absolute or relative time

Waveform label (select channel No. or tag)

Mark on the active waveform  
Click here to make the waveform active

Scroll the screen (up and down)

Scroll the screen (left and right)

Mark (arbitrary mark or trigger mark)

Alarm display (Displays the conditions of alarm 1, 2, 3, and 4 from the left)

| Absolute[No.]                      | CH01 [V] | CH02 [V] | CH [V] |
|------------------------------------|----------|----------|--------|
| 1999/1 2/05 15:36:20.500[00000572] | -0.001   | -0.008   |        |
| 1999/1 2/05 15:36:20.625[00000573] | -0.024   | -0.031   |        |
| 1999/1 2/05 15:36:20.750[00000574] | -0.048   | -0.054   |        |
| 1999/1 2/05 15:36:20.875[00000575] | -0.072   | -0.079   |        |
| 1999/1 2/05 15:36:21.000[00000576] | -0.095   | -0.103   |        |
| 1999/1 2/05 15:36:21.125[00000577] | -0.118   | -0.126   |        |
| 1999/1 2/05 15:36:21.250[00000578] | -0.142   | -0.149   |        |
| 1999/1 2/05 15:36:21.375[00000579] | -0.166   | -0.173   |        |

### General Display Settings of the Numeric Display

Clicking the General Display Settings icon or selecting [View] -[General Display Settings] opens the [General Display Settings] dialog box. Of the parameters in the [General Display Settings] dialog box, those that relate to the numeric display are as follows:

- Turn ON/OFF numeric value display
- Registering the channel

For details related to the setting procedures, see “General Display Settings” in section 4.2, “Displaying the Waveform.”

### Setting the Time Axis

Select [View] - [Absolute Time] or [Relative Time]. Then, select the time display format using [Format].

### Turn ON/OFF the Alarm Display

The alarm conditions of alarms 1 to 4 are displayed on the screen by clicking the alarm display icon or selecting [View] - [Alarm] and turning ON the alarm display. When an alarm is in effect, the indicator is red. When it is not, the indicator is green.

## 4.4 Displaying Numeric Values

### Selecting the Characters Used to Identify Channels

For details, see “Selecting the Characters Used to Identify Channels” in section 4.2, “Displaying the Waveform.”

### Showing/Hiding Cursors

#### Showing the cursor

##### 1. Point the cursor (Cursor A)

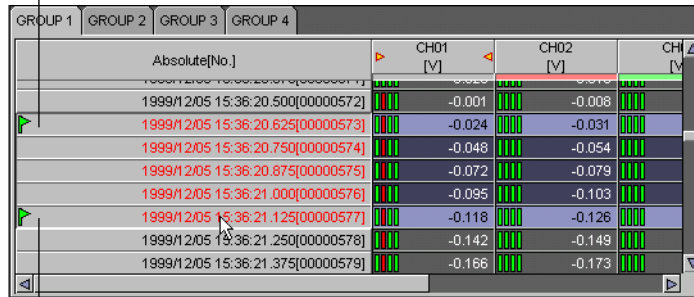

##### 2. Drag the cursor (Cursor B).

By selecting [Edit] - [Select All], Cursor A and Cursor B moves to the beginning and the end of the data, respectively.

#### Showing the cursor value, displaying statistics and hiding the cursor

For details, see “Displaying Cursor’s values,” “Hiding the Cursor,” “Displaying Statistics” in section 4.2, “Displaying the Waveform.”

### Adding Arbitrary Marks, Deleting Marks, and Resetting Marks

For details, see “Adding Arbitrary Marks,” “Deleting Marks,” and “Resetting Marks” in section 4.2, “Displaying the Waveform.”



# 4.5 Linking Files and Saving the Link Settings File

## Linking Files

You can link and display DX100/DX200/DX200C/MV100/MV200 files that have been divided by the auto save function, power failures, or other means (factors).

The files that can be linked are those that exist in the same directory. There are two methods to link files, from the toolbar and from the menu bar.

1. Click here ([File] - [Open]).



2. The [Open] dialog box opens.

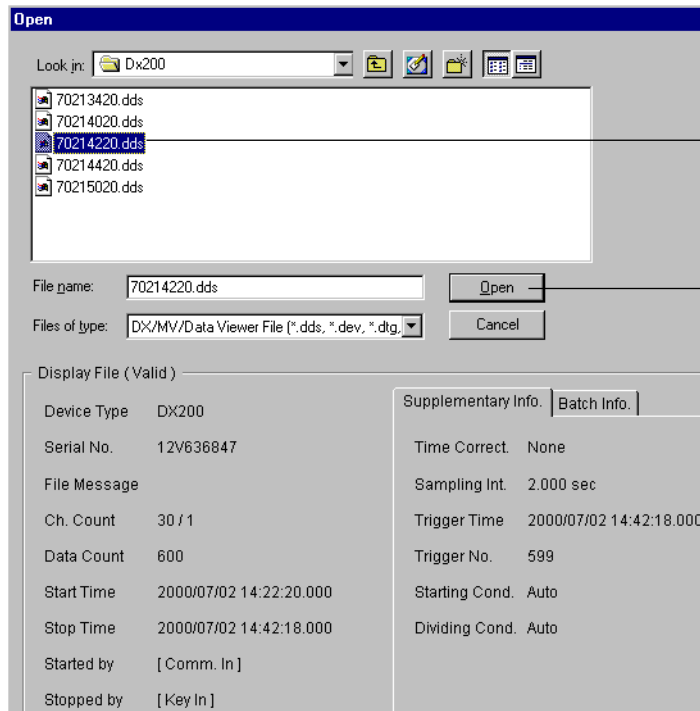

3. Select the initial file.

4. Click here to open the file.

## From the toolbar

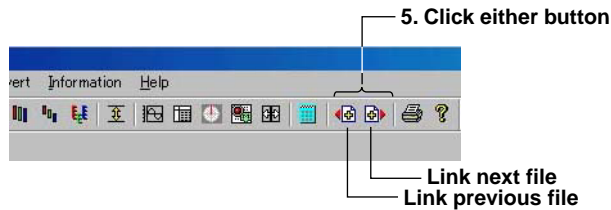

## 4.5 Linking Files and Saving the Link Settings File

From the menu bar

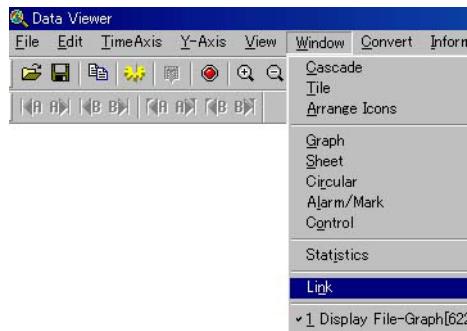

5. Click here([Window]-[Link]).

6. The [Link] dialog box opens.

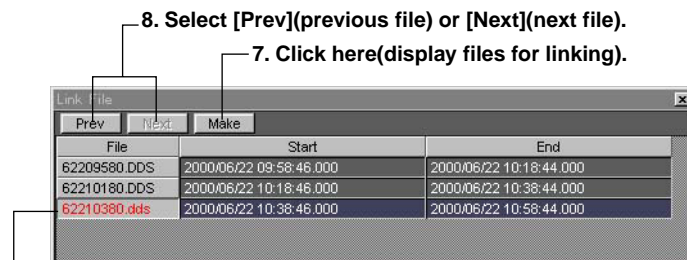

8. Select [Prev](previous file) or [Next](next file).

7. Click here(display files for linking).

9. Displays the linked files.

10. Displays the linked files in a different color.

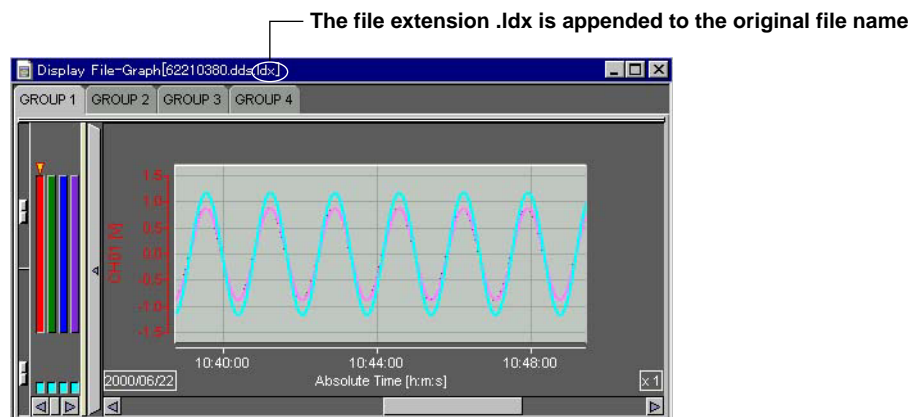

The file extension .idx is appended to the original file name

### Saving the Link Settings File

Select [File] - [Save Display Setting As] to save the link settings file to the same directory as the linked files.

The file name takes the form of the original file name with the file extension .idx.

You can save the file by specifying the file name and the destination directory by selecting [File] - [Save Display Setting].

## 4.6 Listing Alarms and Marks and Converting the List

A list of alarms and marks is displayed with the display file or event file opened.

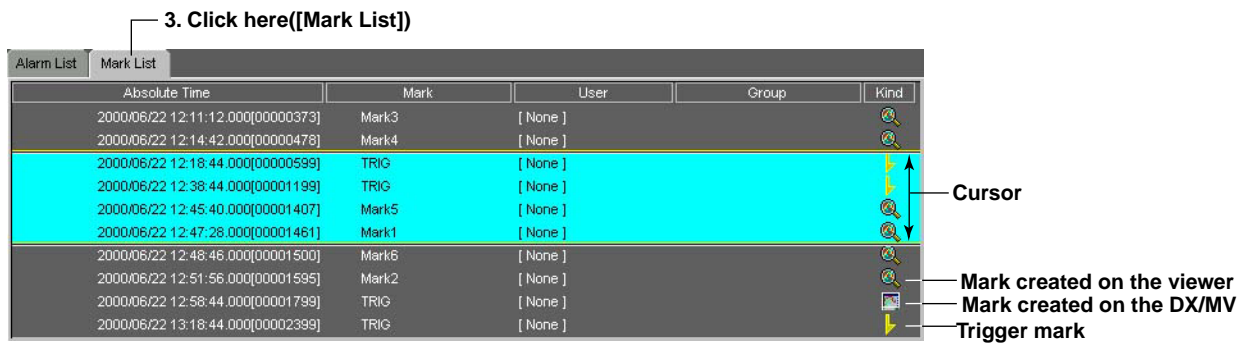
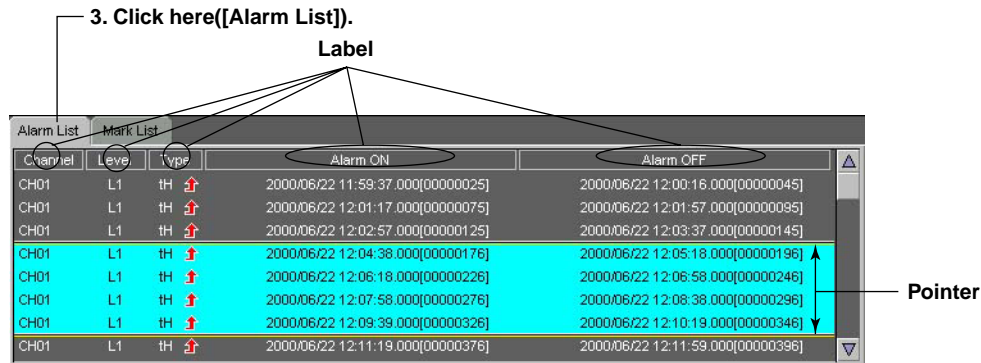
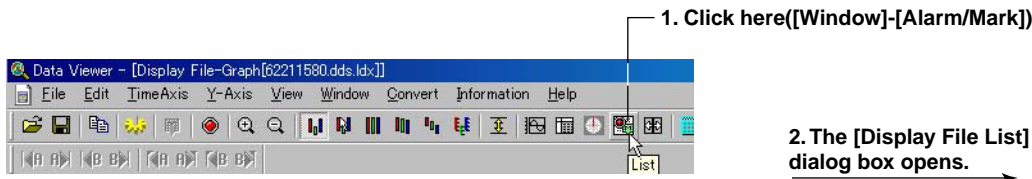

Click a label to sort using the label. The first click will sort the list in the ascending order; the second click will sort the list in the descending order.

### Note

If you drag on the "Alarm List" display screen, a pointer is displayed. The cursor on the waveform display, circular display, numerical display, and cursor value display are not synchronized to this pointer.

## 4.6 Listing Alarms and Marks and Converting the List

### Converting and outputting the alarm or mark list

The Alarm or Mark List can be converted to ASCII, Lotus, and Excel formats.

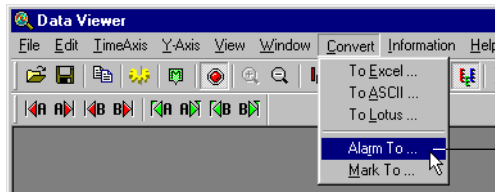

1. Click here([Convert]-[Alarm to] or [Mark to])

2. The [Alarm List] or [Mark List] dialog box opens.



3. Click here.

4. The [Save As] dialog box opens.

6. Click here.

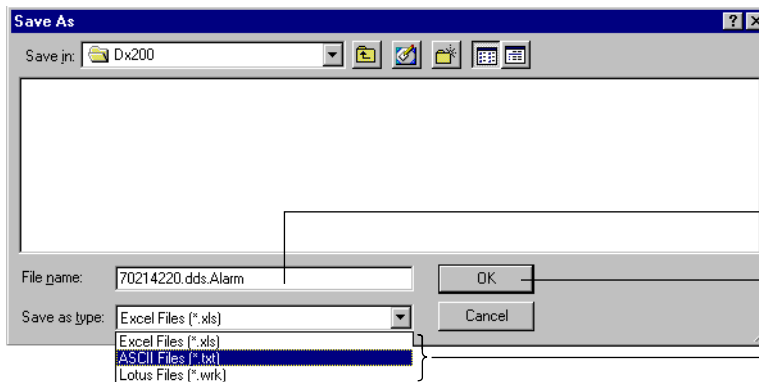

Enter the file name.

5. Set the items and click here.

Select one.

# 4.7 Displaying the TLOG File

## Displaying the TLOG File

1. Click the Open button or select [File] - [Open] from menu bar.

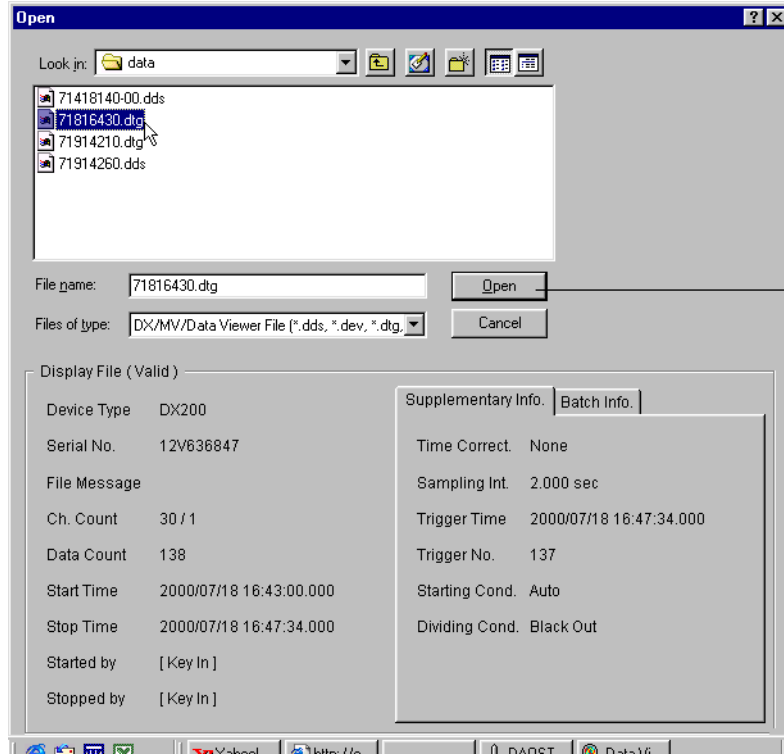

2. Select the desired file and click the [Open] button.

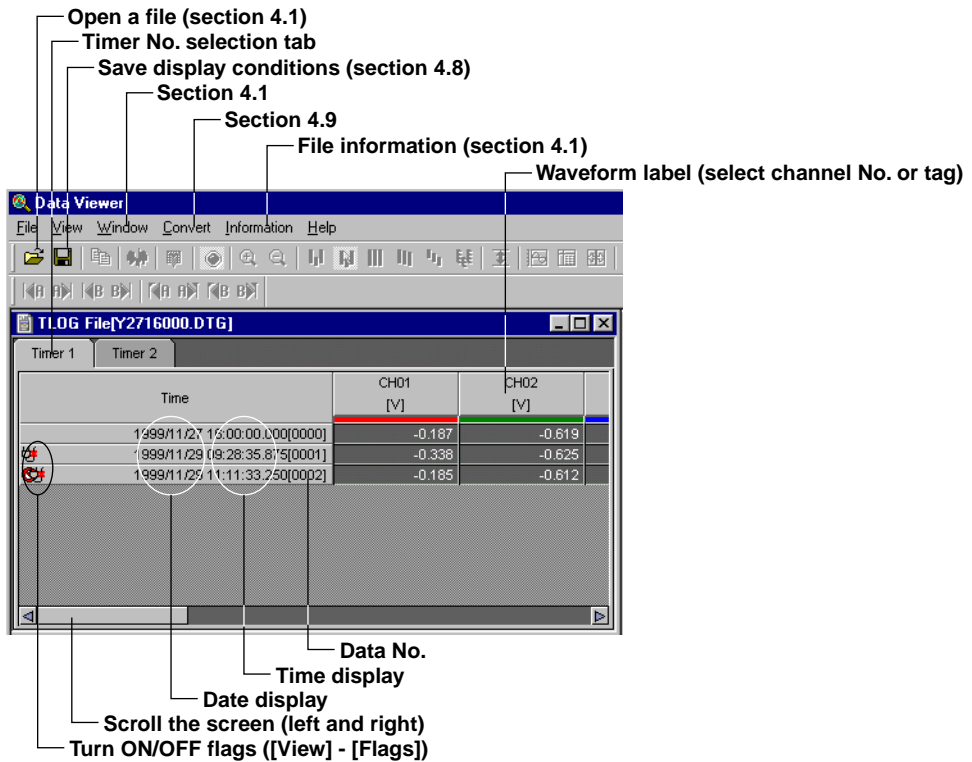

## 4.7 Displaying the TLOG File

---

### Turning ON/OFF Flags

When [View] - [Flags] is checked, the following status information is displayed:

 : Stopped TLOG computation.

 : The DX/MV time and date was changed during TLOG computation.

 : Power failure occurred during TLOG computation.

### Date/Time display

Select [View] - [Date Format] or [Time Format] to select the display format. If [None] is selected, the date or time will not be displayed.

### Data No.

When [View] - [Data No.] is checked, the data number is displayed.

### Selecting the Characters Used to Identify Channels

For details, see “Selecting the Characters Used to Identify Channels” in section 4.2, “Displaying the Waveform.”

## 4.8 Saving the Display Settings

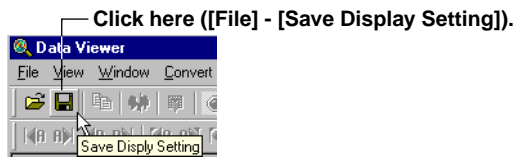

The display settings can be saved to a file. The following display settings can be saved:

### For display file, event file, and link file displays

- Print comment
- Cursor A and Cursor B positions
- ON/OFF condition of the clipping of the displayed waveform
- Settings specified in the General Display Settings
- Mark information
- Zoom rate of the time axis
- Display mode of the time axis (absolute/relative)
- Waveform display area
- The channel identification string mode (channel/tag)
- ON/OFF condition of file information items (see section 4.1)
- The background and grid color of the waveform display area
- Y-axis zone setting
- The active waveform
- The height of the data overview of each group
- The width of the zone display area of each group
- Show/Hide condition of the zone display area
- Selected group
- ON/OFF condition of the alarm display

### For TLOG file display

- ON/OFF condition of TLOG file information items (see section 4.1) and print comment
- The string to be used (channel/tag)
- Timer No.
- Display format of date and time

The information is saved to the same directory as the data files. The name of the saved file is the name of the data file being displayed, with an added [vdx] extension (Y1116040.DDS.vdx, for example).

This display setting file can be overwritten unlimited number of times.

When the data with the same file name is reopened, the display settings that were saved are used. If you do not wish to open the data using the saved settings, delete the display setting file ([vdx] extension) before opening the data file.

## 4.9 Converting the Data



When waveform display or numeric display is open

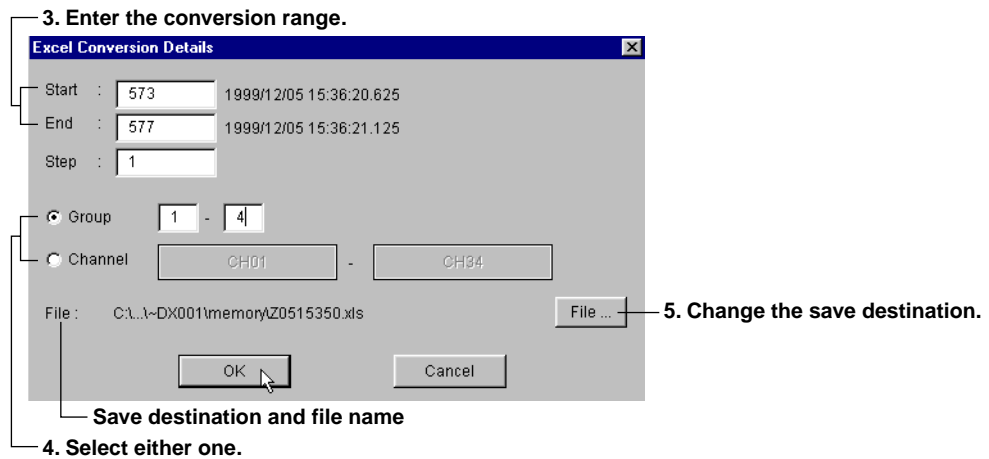

The measured data can be converted to ASCII, Lotus, and Excel formats.

When displaying the TLOG File

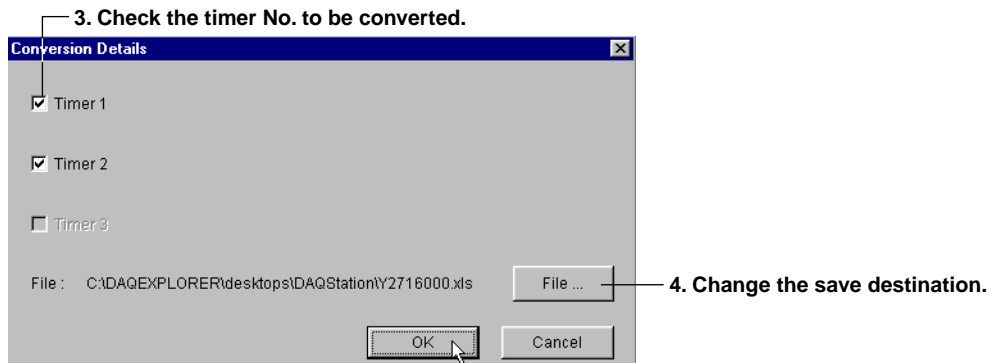



**Start point and end point**

Cursor A and Cursor B are used to set the start point and end point of the range, respectively. If Cursor A and Cursor B are not specified or the cursors were erased, the data numbers of the start and end points are automatically set to [0] and [total number of data points - 1], respectively.

To convert all the data in the specified range, set the step number to 1.

**Step**

To convert all the data in the specified range, set the step number to 1.

**Group/Channel**

If you select [Group], enter the range of groups to be converted.

If you select [Channel], enter the range of channels to be converted.

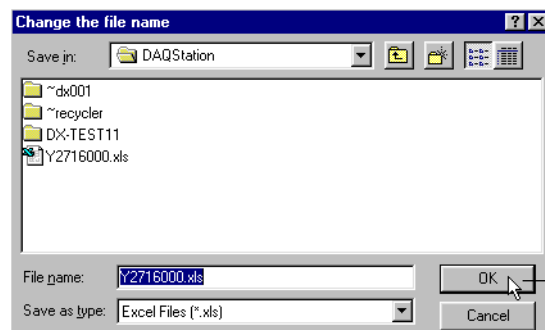
**Changing the save destination**

Select the destination folder and file and click the [OK] button

To change the destination folder or the name of the file containing the converted data, click the [File] button. The [Change the file name] dialog box opens.

**Note**

- The default group is set to the number of the group that is currently being displayed. The default channel is set to all channels.
- The name of the destination file is automatically set to the displayed file name followed by the extension that identifies the data format. For ASCII, Lotus, and Excel conversions, the file extensions [txt], [wrk] (can be loaded using version 2.0 or later, and [xls] (can be loaded by version 4.0 or later) are attached, respectively.
- There is a limit in the number of data points that Lotus1-2-3 and Excel can handle. For these programs, specify the number of data points to be converted before performing the conversion. Note that even if the number of data points to be converted is within the limits, it still may not be possible to load the data if there is not enough free memory available on the PC.
- Do not specify a floppy disk or an external storage medium as the save destination as it will take a long time for the save operation.
- Do not specify the root directory as the save destination.
- Prepare enough free space on the destination disk.



## 4.10 Printing

### Setting the Printer

1. Select [File] - [Print Setup].

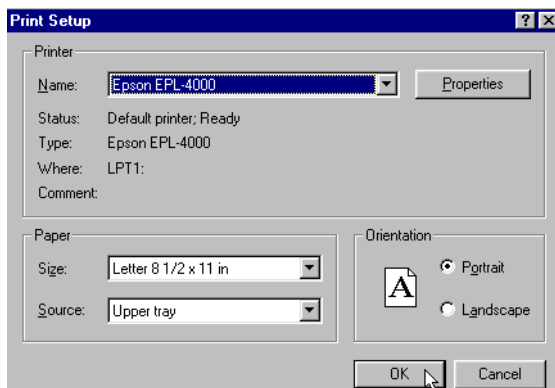

2. Set the printer, paper and orientation.

#### Note

Set the printer according to the configuration of the system that you are using.

### Specifying the Contents to be Printed (for Display Data File and Event Data File)

Specify the contents to be printed before executing the print. This is not necessary when printing the TLOG file.

Select [File] - [Print Settings]. The [Printout Setup] dialog box opens. When the waveform is displayed, printing is carried out according to the settings under the Graph Print tab of the [Printout Setup] dialog box. If numeric values are displayed, printing is carried out according to the settings under the Sheet Print tab.

#### Setting graph print

Click this tab to set the graph print

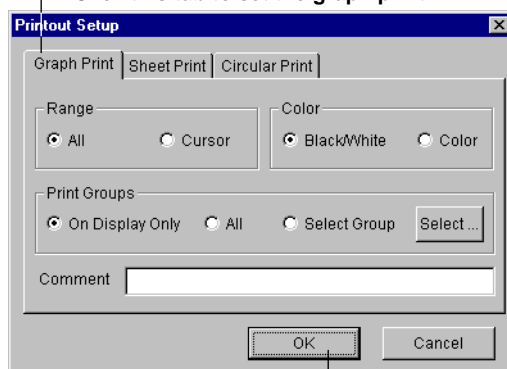

Set the range, color, print group, and comment, then click the [OK] button

## 4.10 Printing

If you selected [Select Group], click the [Select] button. The [Select Groups] dialog box opens. Select the groups to be printed. Click the [OK] button to close the dialog box.

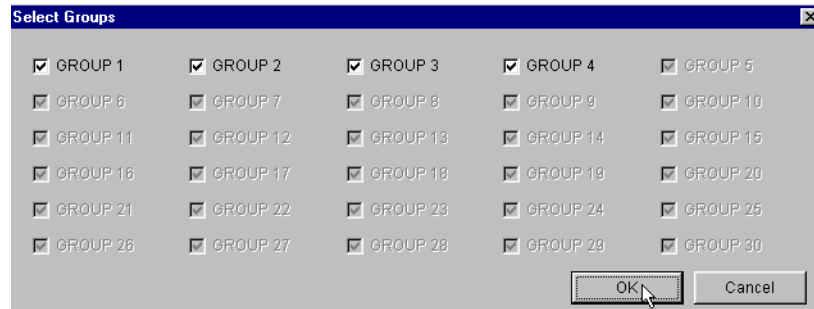

### Note

- The [Comment] can be entered or changed using [About Document] (see “Viewing the information of the loaded file” page 4-3). When the print comment is entered or changed, it is reflected in the comment of [About Document] dialog box.
- Up to 127 characters can be entered in the [Comment] entry box. However, the number of characters that is actually printed is limited.
- When the cursor is not displayed, select the [All] button under [Range] in the [Printout Setup] dialog box.

### Setting sheet print

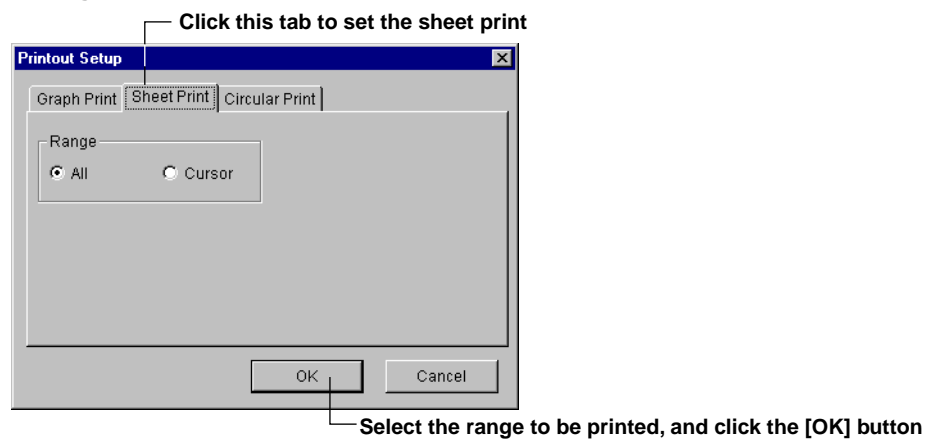

### Setting circular print

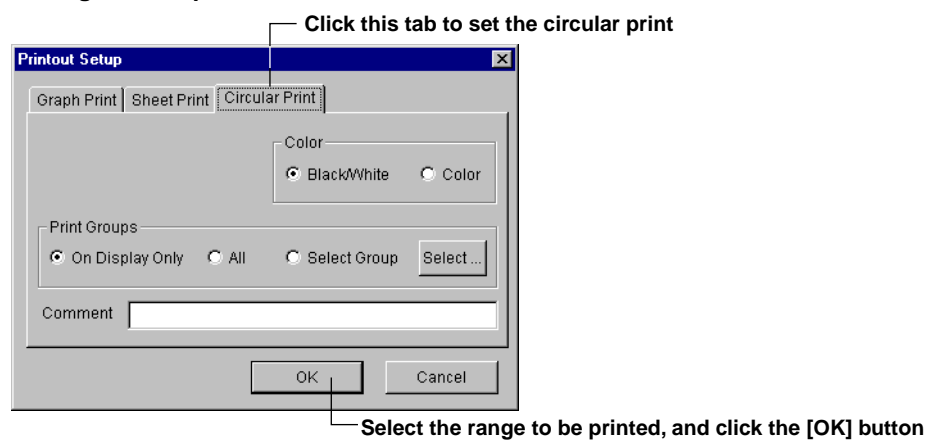

For the operations that follows, see “Setting graph print.”

## Header

A header can be printed when printing the waveform or a TLOG file.

Of the items that are displayed in the file information dialog box ([Information] - [About Document]), those that are checked are printed in the header section. For details related to the file information, see section 4.1.

## Print Preview

You can preview the print layout before actually printing the data.

Selecting [File] - [Print Preview] displays the print preview screen.

### Note

- The preview screen will display the print image of the specified range.
- The file information is also displayed when previewing the graph. If the color overview, alarm, [Cursor value] window, and [Statistics] window are displayed, these are also displayed on the preview screen along with the graph
- For the print preview operation, see the instruction manual that came with your operating system.

## Printing

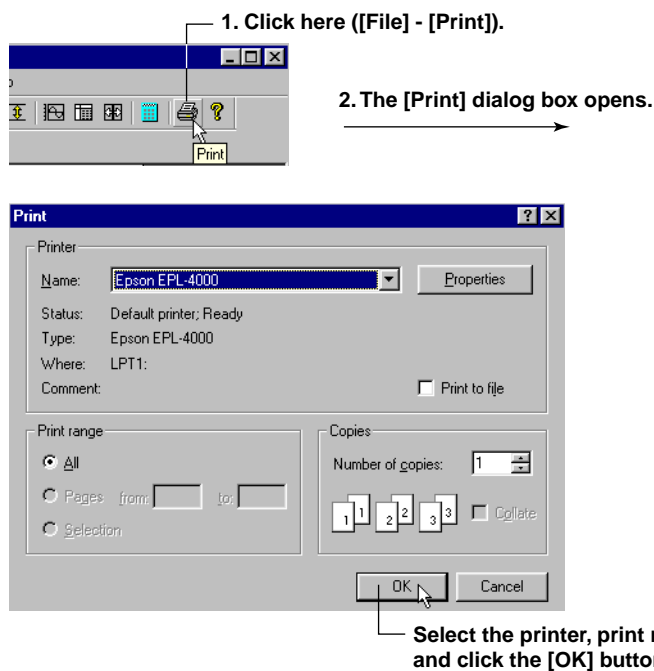

## 5. Troubleshooting

### Launcher

| Message                       | Corrective Action                                     | Reference Pages |
|-------------------------------|---|-----------------|
| Check communication settings. | Open the [Network] dialog box and check the settings. | 2-3             |

### Hardware Configurator

#### Warning Message List

| Message  | Reference Pages |
|--|-----------------|
| System settings have been changed. Input configuration and data will be initialized. Do you want to proceed?           | 3-2             |
| Data created in 2038 or later cannot be handled.   | –               |
| Some A/D converters are faulty. Some items cannot be set.  | –               |
| Some information cannot be set. Do you still want to continue?   | –               |
| Settings may not be made correctly since the configuration does not match the connected DX. Do you still want to send? | 3-25            |
| The current setup data will be initialized.  | 3-12            |
| Setup data will be received from the DX.   | 3-2             |
| The setup data will be sent.   | 3-25            |
| Memory sampling will be stopped.   | 3-28            |
| Memory sampling will be started.   | 3-28            |

#### Error List

| Message   | Corrective Action  | Reference Pages |
|---|--|-----------------|
| Illegal file to load                                | Select another file.   | 3-3             |
| Failed to load the file.                            | Try to load the file again. If still not possible, the file may be damaged. Select another file. | 3-3             |
| Failed to create a file.                            | Check the free space in the directory.   | –               |
| Memory sampling in progress<br>Stop sending.        | Send after data has been written to the internal memory of the DX.                               | 3-25            |
| Math in progress<br>Stop sending.                   | Send after math is completed.  | 3-25            |
| Memory sampling & math in progress<br>Stop sending. | Send after data has been written to the internal memory of the DX and math is completed.         | 3-25            |
| Saving to the media. Re-send later.                 | Send after data has been saved to the external media.  | 3-25            |
| Communication error                                 | Check the communication settings.  | 2-3             |
| Time out  | Traffic may be busy. Retry later.  | –               |
| Illegal user information                            | Check whether the user name is correct.  | 3-19            |
| Failed to connect.                                  | Check the communication settings.<br>Check whether the DX is powered ON.                         | 2-3             |
| Communication busy                                  | Retry later.   | –               |
| Memory error  | Exit other programs then restart, or reboot the OS then restart.                                 | –               |
| User level error                                    | No right is given to the login user ID   | –               |

## 5. Troubleshooting

---

### Message

#### Message

---

Data has been sent.  
Data has been received.  
Some information has not been sent.  
Not allowed.  
A password is required.  
A user name is required.  
Some information requires attention.

---

### Data Viewer

| Message  | Corrective Action  | Reference Pages |
|--|--|-----------------|
| Insufficient memory.<br>Exit immediately.                        | Exit other programs then restart, or reboot the OS then restart.                                       | –               |
| Cannot write to the file.  | Check the free space in the directory. The file may be currently used by another program, so check it. | –               |
| Cannot load the file.  | Check whether the file exists.<br>Also check whether the file system is correct.                       | –               |
| Cannot open the file.  | Check whether the file exists. Also check whether the file system is correct.                          | –               |
| Illegal file   | Select another file.   | 4-2             |
| The number of data sets is "0".                                  | Select another file.   | 4-2             |
| The number of channels is "0".                                   | Select another file.   | 4-2             |
| Some files may be overwritten.<br>Do you still want to continue? | Continue if OK. If not, change the file names.   | 4-29            |

---

# Index

## A

A/D integrate ..... 3-17  
 About Document ..... 4-3, 4-33  
 abnormal data ..... 4-13  
 absolute time ..... 4-7, 4-19  
 adjust the setup data ..... 3-25  
 alarm ..... 3-6, 3-16  
 alarm delay ..... 3-6  
 alarm display ..... 4-11, 4-19  
 alarm list ..... 4-23  
 alarm transition point ..... 4-14  
 alarm value ..... 3-6  
 arbitrary mark ..... 4-14  
 auto save interval ..... 3-12  
 auto zone ..... 4-8

## B

Batch function ..... 3-22  
 bar graph ..... 3-7  
 boundary ..... 3-7  
 burnout ..... 3-18

## C

Channel ..... 3-18, 4-29  
 Circular ..... 4-17  
 Circular print ..... 4-32  
 Converting the Data ..... 4-28  
 change the destination folder ..... 4-29  
 channel No. .... 4-11  
 check the data ..... 3-25  
 check the system configuration ..... 3-27  
 clip ..... 4-10  
 clipboard ..... 4-12  
 color overview display ..... 4-4  
 constant ..... 3-10  
 convert the reference unit time ..... 3-21  
 converting the data ..... 4-28  
 copy ..... 3-7, 4-7, 4-12  
 cursor's value ..... 4-13

## D

Data No. .... 4-26  
 Date Format ..... 4-26  
 Daylight Saving ..... 3-15  
 Display update interval ..... 3-12  
 data adjustment ..... 3-25  
 data number ..... 4-26  
 decimal point ..... 3-5  
 delete the mark ..... 4-15  
 difference computation ..... 3-5  
 display color ..... 3-7, 4-7  
 display numeric value ..... 4-19  
 display position ..... 4-6  
 display range ..... 4-6  
 display span ..... 3-5, 3-10  
 display zone ..... 3-6  
 displaying the waveform ..... 4-4  
 division ..... 3-7

## E

edit zone ..... 4-8, 4-10  
 end point ..... 4-29  
 event file ..... 4-27

## F

FTP ..... 3-23  
 file ..... 3-13  
 file header ..... 3-13  
 flag ..... 4-26  
 full zone ..... 4-8

## G

Group ..... 4-29  
 general display setting ..... 4-5  
 graph ..... 3-7  
 graph print ..... 4-31  
 group ..... 3-14, 4-5  
 group name ..... 3-14, 3-15

## H

Hide Cursor ..... 4-12  
 header ..... 4-33

## I

initialize ..... 3-27  
 initialize the setup data ..... 3-27  
 input filter ..... 3-6  
 input type ..... 3-5  
 interval ..... 3-10

## K

key lock ..... 3-19

## L

LACK ..... 4-13  
 Link Settings File ..... 4-22  
 language ..... 3-22  
 link file ..... 4-21, 4-27  
 list of alarms ..... 4-23  
 list of marks ..... 4-23  
 login ..... 3-19

## M

Mark list ..... 4-23  
 manual save ..... 3-13  
 mark ..... 4-14  
 mark position ..... 4-14  
 memory alarm time ..... 3-22  
 memory sample ..... 3-17  
 message ..... 3-13  
 mode ..... 3-5  
 moving average ..... 3-6  
 multi-axis zone ..... 4-8



## Index

---

### N

---

network ..... 3-23  
number of block ..... 3-17  
number of channel ..... 3-14  
number of sample ..... 3-10

### O

---

OVER ..... 4-13  
Open ..... 4-2  
operator ..... 3-11

### P

---

Pre-Trigger length ..... 3-17  
Print Preview ..... 4-33  
partial expanded display ..... 3-7, 3-22  
password ..... 3-19  
paste ..... 3-7, 4-7  
position ..... 3-7  
print ..... 3-29, 4-31  
print preview ..... 3-29

### R

---

RJC ..... 3-18  
Reset Mark ..... 4-15  
range ..... 3-5  
reference channel ..... 3-5  
registering the channel ..... 4-6  
relative time ..... 4-7, 4-19  
relay ..... 3-6  
relay AND ..... 3-16  
remote ..... 3-16  
report channel ..... 3-21  
rolling average ..... 3-10

### S

---

Save ..... 3-17, 3-28  
Save As ..... 3-28  
Select All ..... 4-20  
Select Group ..... 4-32  
Select Groups ..... 4-32  
save the display setting ..... 4-27  
scale ..... 3-5, 3-7  
scale value ..... 4-6  
scan interval ..... 3-17  
screen display ..... 3-12  
screen type ..... 3-15  
send ..... 3-26  
serial communication ..... 3-24  
setting one channel at a time ..... 3-8  
setting one computation channel at a time ..... 3-11  
setup ..... 3-19  
setup mode ..... 3-16  
sheet print ..... 4-32  
showing the cursor ..... 4-12  
slide zone ..... 4-8  
square root ..... 3-5  
start point ..... 4-29  
starting the DX Configurator ..... 3-2  
starting the Data Viewer ..... 4-1  
statistics ..... 4-13  
step ..... 4-29

sum scale ..... 3-10  
system configuration ..... 3-27

### T

---

TCP/IP ..... 3-23  
TLOG computation ..... 3-10  
TLOG file ..... 4-25  
Time Format ..... 4-26  
tag ..... 3-6, 3-22, 4-11  
temperature unit ..... 3-22  
timer ..... 3-10, 3-20  
trip line ..... 3-14  
type ..... 3-5, 3-6

### U

---

USER Key ..... 3-15  
User ID ..... 3-19  
user name ..... 3-19  
user zone ..... 4-8

### V

---

view group ..... 3-15

### W

---

waveform display limit ..... 4-10

### Y

---

Y-axis ..... 4-6, 4-8

### Z

---

zone ..... 3-6, 4-6, 4-8  
zoom in ..... 4-7  
zoom out ..... 4-7